

Gigaset

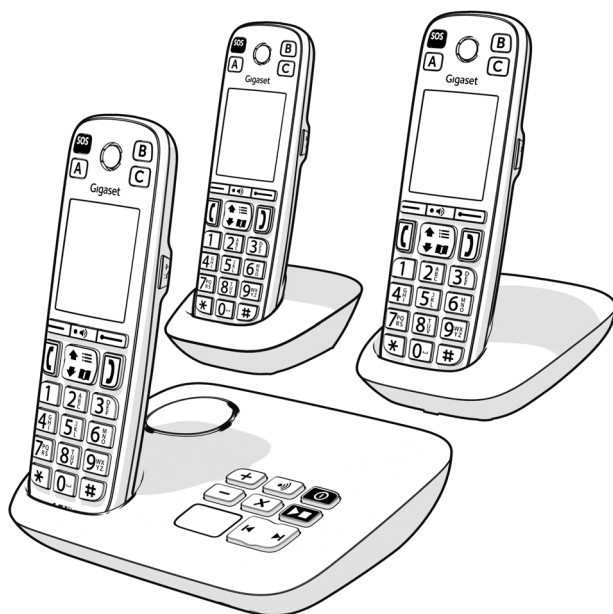

EASY 500
EASY 500 A
EASY 500 HX

The most up-to-date user guide
can be found at
www.gigaset.com/manuals



Contents

Notation in the operating manual	5
Menu overview	6
Overview	9
Base unit with answering machine	9
Base unit without answering machine	10
Handset	11
Safety information	13
Getting started	15
Package contents	15
Connecting the base unit	17
Connecting the charging cradle	19
Putting the handset into operation	20
SOS emergency call	22
Operating the telephone	25
Getting to know the telephone	25
Making/Taking calls	28
Provider-specific functions (Network services)	32
Call lists	39
Call lists	39
Phone books	41
Contacts in the phone book	41
Answering machine and announcements	44
Activating/Deactivating the answering machine	44
Setting the network answering machine	44
Operation with the handset	45
Announcements	48
Recordings	50
Changing the language for voice guidance and standard announce- ment	51

Further functions	52
Add more devices	52
Room monitoring	54
ECO DECT	55
Protection from unwanted calls	56
Settings on the handset	58
Setting the date and time	58
Displaying the language	58
Country	59
Boost key	59
Tones and signals	60
Display	64
Telephony	66
System	68
Operating aids	71
Direct dialing keys	71
Announcements	73
Brightness	75
LED call alert signal	76
Serious caller	77
Simple menu	77
Allowing the handset to be switched off	78
Direct extension for emergencies (for EASY 500 and EASY 500HX on one router)	78
Direct extension for emergencies (for EASY 500A)	81

Appendix	84
Customer service & help	84
Manufacturer's information	84
Technical data	90
Symbols	94
Index	96







Not all functions described in the user guide are available in all countries or from all network providers.

Notation in the operating manual

This chapter describes the various forms of notation used in the operating manual and the respective significance.

Symbols

	Warnings, which, if not observed, can result in personal injury or damage to equipment.
	Important information regarding the function and proper handling or functions that could generate costs.
	Condition which must be fulfilled in order to carry out the following action.
	Additional helpful information.

Working steps

- 1 First working step.
 - 2 Further working step.
- ▶ Result of the series of working steps

Display texts



Display texts are texts which appear on the display of the mobile phone. Display texts are displayed in **bold print**.

Example:

Press the **OK** display key.

Control key

Display of the Control key in the manual:

-  Press the "Up" button.
-  Press the "Down" button.
-  Press the "Up" or "Down" button.

Menu overview

1 When in standby, press the Control key  to open the menu.



Handset Directory



Call Lists

Redial List

All calls

Accepted calls

Missed calls



Answering Machine

Play Messages

Activation

Answer & Record

Announcements

Recordings

Call Screening

Network Mailbox

Language



Audio Settings

Handset Volume

Handsfree Volume

Ringtones (Handset)

Acoustic Profiles

Ringtones (Base)

Volume

Melodies

Earpiece Profiles

Handsfree Profiles

Advisory Tones
Music on Hold

Key Tones
Confirmation
Battery
Out of Range



Accessibility
Direct Dial Keys
Acoustic
Brightness
Signal Call via LED
Simple Menu
Switch off Handset

Talking Dial Keys
Language Read Aloud
Caller ID
Read Aloud Directory

Simple Menu
Menu List



Safety
Protect Incoming Calls
Supervision Call
Room Monitor
Trusted Caller
Anon. Calls Silent

Blocklist
Anonymous Calls
Handset
Activation
Allowlist
Activation
Send Alarm to
Two Way Talk
Sensitivity



Help Call Settings
Activation



Settings
Date/Time
Display
Language
Country
Registration
Telephony
System
ECO DECT

Screensaver
Large Font
Colour Scheme
Backlight

Register Handset
Legacy Registration
De-register Handset
Auto Answer
Access Code
Dialling Mode
Recall
Handset Reset
Base Reset
Encryption
System PIN
Maximum Range
No Radiation



Select Services
Next Call anon.
Call Divert
Call Waiting
All Calls anon.
Ringback off

Overview

Base unit with answering machine

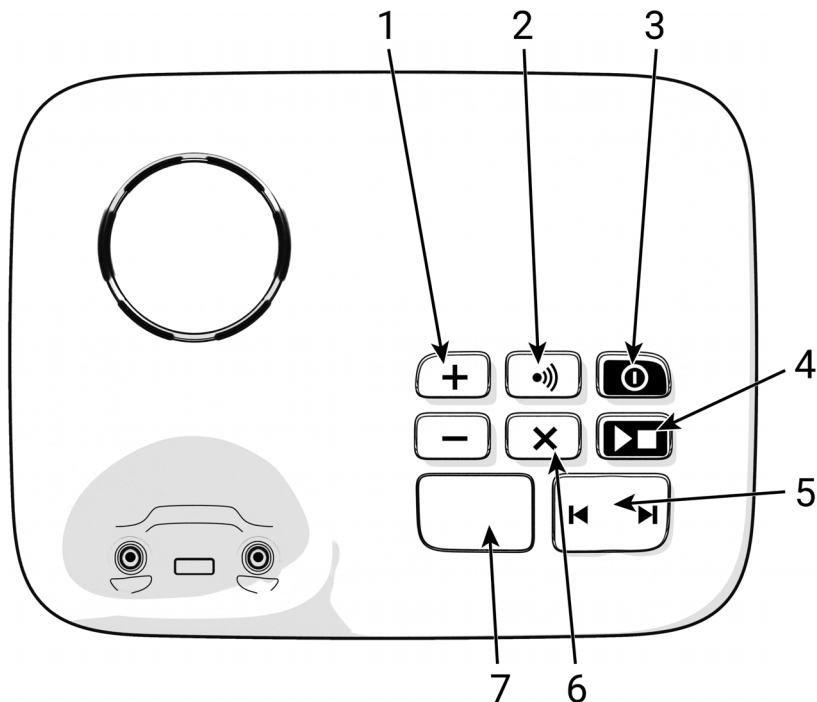

1 Volume buttons

During playback:

Change voice volume.

2 Login/Paging button

Search for handsets (paging)

Register handset

3 On/Off button

Switch answering machine on/off

4 Play/Stop button

Play new messages

No new messages:

Play back old messages or cancel playback.

5 Forward/Back button

During message playback: Skip to the next message.

During playback (after 5 seconds): Skip to the beginning of the message.

During playback (up to 5 seconds): Skip to the previous message.

6 Delete button

During playback: Delete current message.

7 Display

Lights up:

The answering machine is switched on. The number of messages saved is displayed.

00 flashes:

The line is busy.

Flashes slowly:

New messages are available. The number of new messages is displayed.

99 flashes quickly:

The answering machine is full.



If the answering machine is operated from a handset or if it is recording a message (00 flashes in the display), it cannot be operated simultaneously via the base unit.

Base unit without answering machine

1 Login/Paging button

Search for handsets (paging)

Register handset:

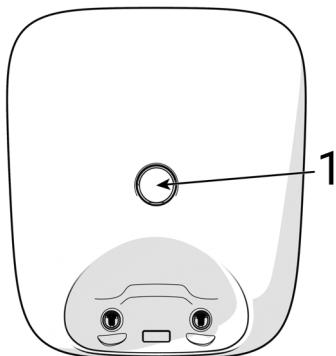

Handset

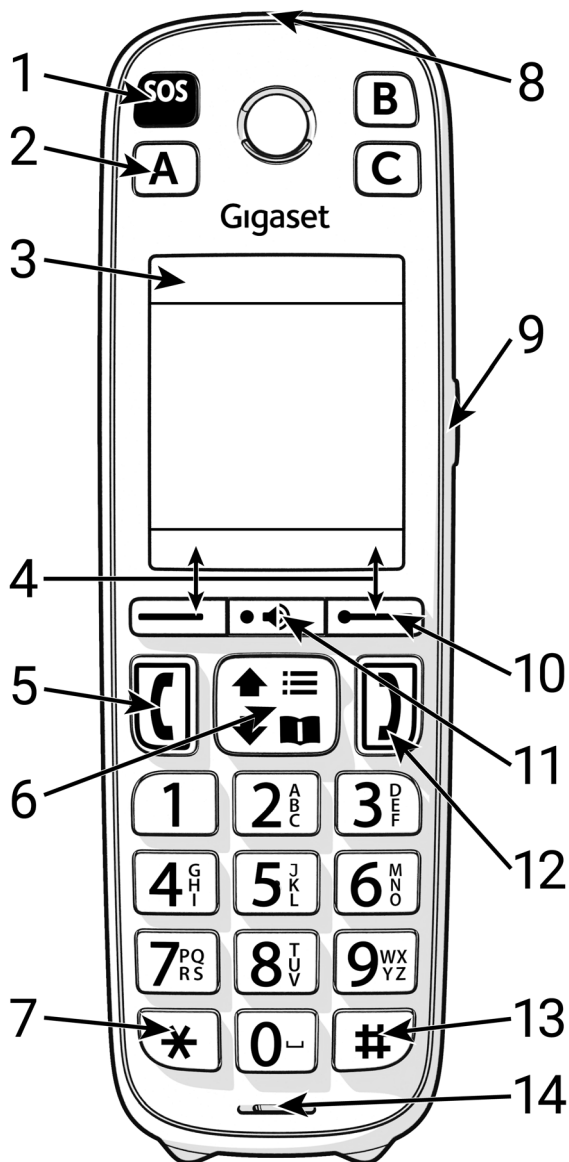

1 SOS key

Lights up: The SOS call function is activated.

2 Direct dialing buttons A to C

3 Status bar

Icons indicate the current settings and operating status of the phone.

4 Display keys

Various functions, depending on the operating situation

5 Call key

Accept call; dial number displayed

6 Control key / Menu key

 Open the menu

 Open the phone book

Navigate through menus and input fields

Call up functions

7 Star key

Open table of special characters

8 Indicator lamp (LED)

Flashes: incoming call or SOS call has been started

9 Boost button

Switch the boost function (caller voice extra-loud) on/off during a call

10 Message key

Access to the call and message lists

Flashes: New voice message, new call

11 Handsfree key

Switch between handset and handsfree mode; accept call; dial number displayed

Lights up: Handsfree mode is switched on

Flashes: Incoming call

12 Hang up key

End call; cancel function; move back one menu level

13 Hash key

Switch between uppercase, lowercase and digits

14 Microphone

Safety information



Read the safety precautions and the user guide before use.



The device cannot be used in the event of a power failure. In case of a power failure it is also not possible to make emergency calls.



Use only **rechargeable batteries** that correspond to the **specification** (see list of permitted batteries → www.gigaset.com/service). Never use a conventional (non-rechargeable) battery or other battery types as this could result in significant health risks and personal injury. Rechargeable batteries, which are noticeably damaged, must be replaced.



The handset must not be operated if the battery cover is open. Ensure that the batteries can not be short-circuited by objects in the battery compartment.



Do not use the devices in environments with a potential explosion hazard (e.g. paint shops).



The devices are not splashproof. For this reason do not install them in a damp environment such as bathrooms or shower rooms.



Use only the power adapter indicated on the device.



Remove faulty devices from use or have them repaired by our Service team, as these could interfere with other wireless services.



Do not use the device if the display is cracked or broken. Broken glass or plastic can cause injury to hands and face. Send the device to our Service department to be repaired.

Do not hold the rear of the handset to your ear when it is ringing or when speaker mode is activated. Otherwise you risk serious and permanent damage to your hearing.



The phone may cause interference in analogue hearing aids (humming or whistling) or cause them to overload. If you require assistance, please contact the hearing aid supplier.

Keep small cells and batteries, which can be swallowed, out of the reach of children.



Swallowing a battery can lead to burns, perforation of soft tissue and death. Severe burns can occur within 2 hours of swallowing.

In the case of a swallowed cell or battery, seek medical care immediately.



To prevent loss of hearing, avoid listening at high volume over long periods of time.



Using your telephone may affect nearby medical equipment. Be aware of the technical conditions in your particular environment, e.g. doctor's surgery. If you use a medical device (e.g. a pacemaker), please contact the device manufacturer. They will be able to advise you regarding the susceptibility of the device to external sources of high frequency energy (for the specifications of your Gigaset product see "Technical data").



Only shielded cables should be used to connect the telephone to the local network.

Getting started

Package contents

- 1 base unit (with or without answering machine, depending on version)
- 1 charging cradle (if available)
- 1 handset
- 1 operating manual

Package contents for the base unit

1 base unit

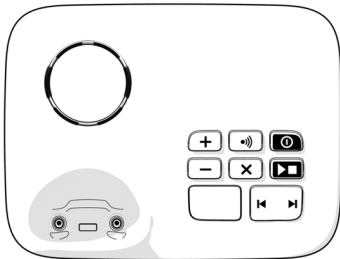

Example: with answering machine



Example: without answering machine

1 plug-in power adapter; 1 telephone plug

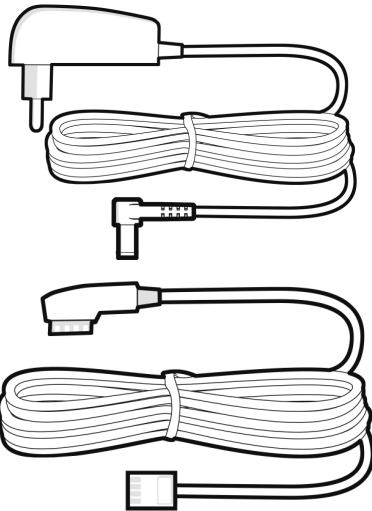

Package contents for the charging cradle

1 charging cradle

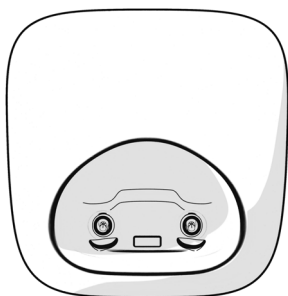

1 power adapter

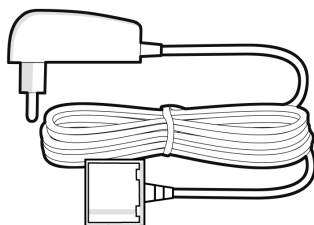

Package contents for the handset

1 handset

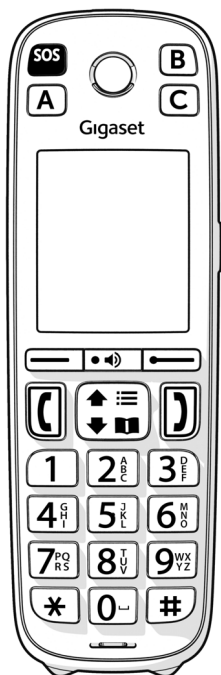

2 batteries; 1 battery cover

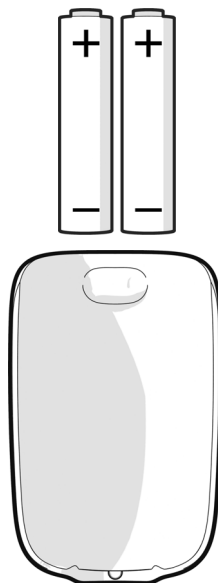

Connecting the base unit

The display of the base unit is protected by a film. Remove the protective film before connecting the base unit.



If you do not plan to use your telephone for several weeks, disconnect the base unit from the mains and remove the batteries from the handset.

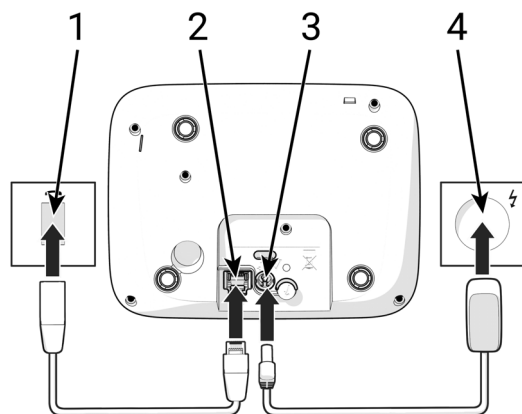

Base unit with answering machine

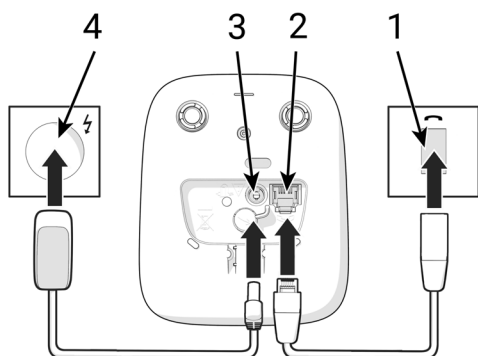

Base unit without answering machine

- 1 Plug the telephone cable into the connection socket **2** until it clicks into place.
- 2 Plug the power cable of the power adapter in the connection socket **3**.
- 3 Connect the power adapter **4** in a properly installed power socket.

Connecting the base unit

4 Insert the telephone plug **1** in the TAE socket.

When connected to a router

1 Insert the telephone plug in the connection socket on the router **5**.

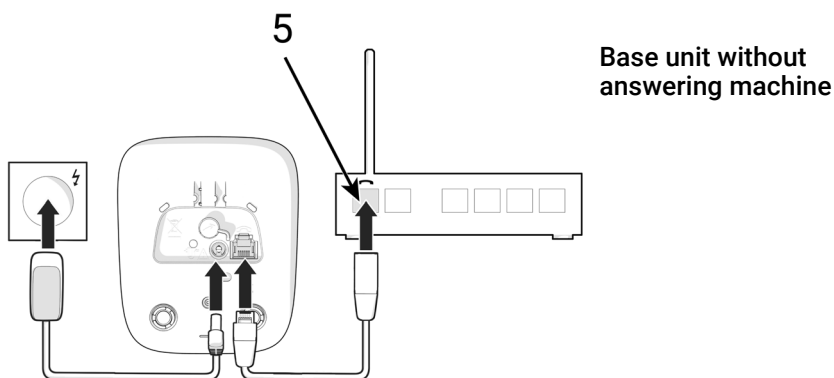
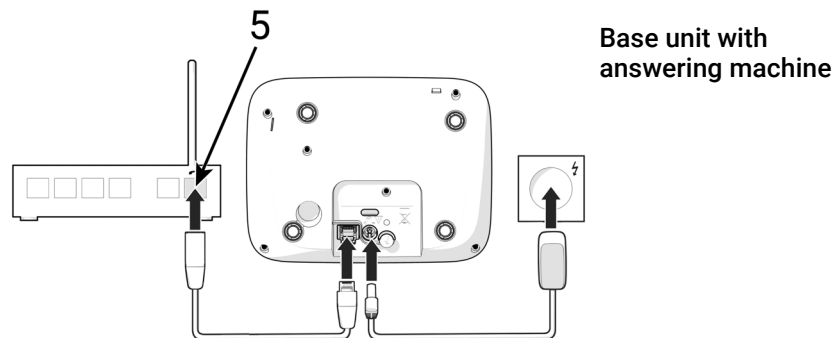

The power adapter must be **plugged in** for operation, as the telephone will not work without a power connection.



When connecting to a router, note the maximum range of the base unit to the handset. If the distance between the base unit and handset is too far, the voice quality of the wireless connection may deteriorate.



The telephone is designed for operation in indoor, dry rooms within a temperature range of +5 °C to +45 °C.

Place the base unit in a central location in the apartment or house on a level, nonslip surface. Normally, the device's feet do not leave any marks on the installation surface. However, given the variety of lacquers and polishes used on furniture, it cannot be ruled out that contact will leave marks on the installation surface.

Never expose the phone to sources of heat, direct sunlight or other electrical devices. Protect the phone from moisture, dust, aggressive liquids and vapors.

Connecting the charging cradle

1 Slide the flat plug **2** of the plug-in power adapter in the charging cradle.

▶ The flat plug engages audibly.

2 Connect the power adapter **1** in a properly installed power socket.

To disconnect the power adapter from the charging cradle:

1 Disconnect the power adapter **1** from the mains.

2 Press the release button **3** on the charging cradle.

3 Disconnect the flat plug **2**.

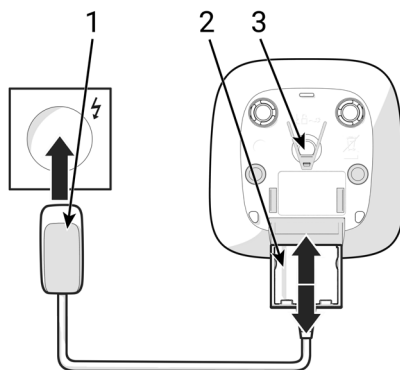

Putting the handset into operation

The display is protected by a film. Remove the protective film before using the handset!

Inserting the batteries



Only use **rechargeable batteries**, otherwise there is a risk of serious damage to health and property. For example, the battery casing could be destroyed or the batteries could explode. It could also cause malfunctions or damage to the device.

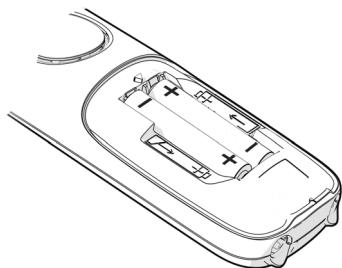

- 1 Insert the batteries in the handset (see illustration for insertion direction +/-).

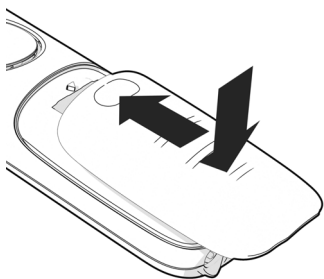

- 1 Assemble the battery cover from above.
- 2 Slide the cover to close it until it clicks into place.

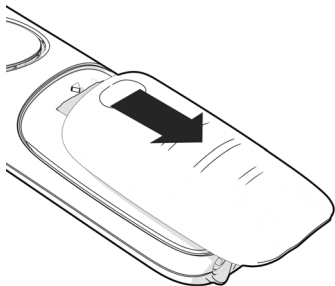

- To remove the battery cover again:
- 1 Insert your fingernail into the groove at the top of the cover.
 - 2 Slide the cover downwards.

Charging the battery

Ensure the battery is charged fully before starting to use the phone for the first time.

The batteries are fully charged when the lightning symbol  disappears from the display.



The batteries can heat up during charging. This is not dangerous.



The charging capacity of the batteries is reduced after some time for technical reasons.

If you will not be using the handset for several weeks, remove the batteries.





The handsets contained in the packaging are already registered to the base unit. If a handset is still not registered (**Please register handset** appears in the display), register the handset again.

Setting the date and time

- 1 Press the **Set Time** display key.
 - 2 Enter the date using the keypad .
 - 3 Enter the time using the keypad .
 - 4 Press the **Save** display key.
- ▶ You have set the date and time.

SOS emergency call

You can set up to 4 phone numbers as SOS emergency numbers. If the SOS emergency call function is activated, you can trigger an SOS emergency call when the handset is idle by pressing the SOS key .

The SOS emergency call is activated: The SOS key  lights up red.

The SOS emergency call is not activated: The SOS key  does not light up.

Procedure



The SOS emergency call function is set up.

Starting an SOS emergency call on the handset:

1 Press the SOS key .

You will hear the announcement over the loudspeaker of your handset:

"Emergency call is being sent."

The recipient of the SOS emergency call hears the SOS emergency call text:

"This is an emergency call. To accept the emergency call, please press .

If the called party accepts the call and then presses  key: They can talk to each other.

If the called party does not answer the call: The SOS emergency call function automatically dials the next SOS emergency call number after 40 seconds (if several numbers are stored).

The SOS emergency call function also automatically switches to the next SOS emergency number after approx. 1 minute in the following situations:

- The answering machine of the selected SOS emergency number is switched on.
- The SOS emergency number is busy.
- Acceptance of the SOS emergency call is not confirmed with the  button.

The sequence is repeated a maximum of 5 times. If none of the calls are answered, the SOS emergency call function is terminated after up to 10 minutes with an error tone.

Canceling the SOS emergency call

If you have triggered an SOS emergency call by mistake, you can cancel it.

- 1 Press the Hang Up key .

Setting up an SOS emergency call









The police, rescue service or fire department may not be used for the SOS emergency call.



Test the SOS emergency call after setting it up. This guarantees that the SOS emergency call works.

Saving SOS emergency numbers

- 1 Press the Control key  to open the menu.
- 2 Select **Help Call Settings**.
- 3 Confirm the selection using the OK display key.
- 4 Select one of the SOS call numbers.
- 5 Press the Edit display key.
- 6 Enter the phone number using the keypad .
- 7 Press the Control key .
- 8 Enter the first name using the keypad .
- 9 Press the Control key .
- 10 Enter the surname using the keypad .
- 11 Press the Save display key.



Instead of entering a new number, you can also select a number from the phone book as an SOS emergency contact.



If no SOS emergency number is specified, the SOS emergency call is deactivated.

Change/Delete emergency numbers

- 1 Press the Control key  to open the menu.
- 2 Select **Help Call Settings**.
- 3 Confirm the selection using the **OK** display key.
- 4 Select one of the SOS call numbers.
- 5 Press the **Edit** display key.
- 6 Delete the existing text by pressing the **<C** key in the display.
- 7 Edit the entry as required.
- 8 Press the **Save** display key.

Operating the telephone

Getting to know the telephone

Control key



The control button is used to navigate in menus and input fields and to call up certain functions depending on the situation.

In the following section, the side of the control button to be pressed in the respective operating situation is marked with an arrow (up, down), e.g.  for "press the top of the control button".



The possible navigation directions are indicated by arrows in the display.

In Standby mode:

- Open the main menu: ▶ Press the Control key .
- Open the phone book: ▶ Press the Control key .

During a call

- Changing the voice volume for handset and handsfree mode: ▶ Press the Control key .

In submenus, selection and input fields

- Confirm function/selection: ▶ Press the OK display key.

Display keys

The display keys provide different functions depending on the operating situation.

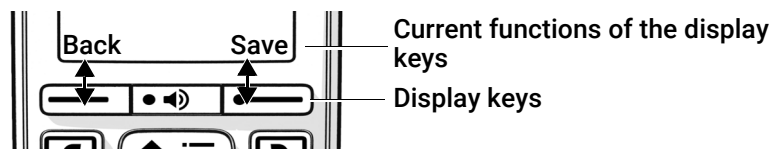







- 1 Press the respective key in the display.
 - ▶ The function shown on the display is called up.

Changing the assignment of the left-hand display key

- 1 Press and hold the left-hand display key for 3 seconds.
- 2 Select one of the functions displayed.
- 3 Press the OK display key.
 - ▶ You have changed the assignment of the display buttons.

Menu navigation

The functions of your phone are provided via a menu consisting of several levels.

- Open the main menu: ▶ When in standby, press the Control key .
- To open a submenu:
 - 1 Select the submenu required using the Control key .
 - 2 Confirm the selection using the display key OK.
- One menu level back: ▶ Press the Back display key.
- or
- ▶ Press the Hang Up key  briefly.
- Select entry/function: ▶ Press the OK display key.
- Switch the function on/off: ▶ Press the display key Edit ( = activated /  = deactivated).
- Activate/deactivate option: ▶ Press the display key Select ( = selected /  = not selected).

After approx. 50 seconds of inactivity, the display automatically switches to Standby mode.

Entering text

Each key between **2** and **9** and the **0** key are assigned several letters and digits. As soon as a key is pressed, the possible characters are shown at the bottom of the display. The selected character is highlighted.

Selecting letters/digits: ▶ Press the relevant key several times in quick succession.

Switch between lowercase, uppercase and digits: ▶ Press the Hash key **#**.

When editing a phone book entry, the first letter and each letter following a space are automatically capitalized.

Enter special characters: 1 Press the Star key *****.
2 Use the Control key to navigate to **↕** the required character.
3 Press the insert display key.

Select the input field: ▶ Use the Control key **↕** to select the required character.



A field is activated when the flashing cursor is displayed in it.

Delete characters preceding the cursor: ▶ Press the **←C** display key.



 The availability of special characters depends on the language set.

Making/Taking calls

Making calls



- 1 Enter the phone number using the keypad .
- 2 Press the Call key .
- ▶ The connection is dialed via the transmission connection (line) set for the handset.

Dialing from the phone book

- 1 Press the Control key  to open the phone book.
- 2 Select the entry required.
- 3 Press the Call key .
- ▶ You have dialed a phone number.





You can also dial a number from the handset phone book:

- 1 Press the Control key  to open the menu.
- 2 Select **Handset Directory**.
- 3 Press the **OK display key**.
- 4 Select the entry required.
- 5 Press the Call key .

Dialing from the redial list



The redial list contains the last numbers dialed on this handset.

- 1 Press the Call key .
- 2 Select the entry required.
- 3 Press the Call key .

or





The left-hand display key is assigned the redial function.

- 1 Press the  display key.
- 2 Select the entry required.
- 3 Press the Call key .

Making calls from a call list

There are call lists for outgoing, received or missed calls.

- 1 Press the Control key  to open the menu.
- 2 Select **Call Lists**.
- 3 Press the **OK** display key.
- 4 Select the call list required.
- 5 Press the **OK** display key.
- 6 Select the entry required.
- 7 Press the Call key .



The list of missed calls can also be opened using the Message key .

Taking calls

An incoming call is indicated by a ringing tone, an indicator in the display and flashing of the answer button.

The display shows

- the name of the caller, if stored in the phone book,
- the number of the caller, if transmitted.

Taking a call: 1 Press the Call key .

If automatic call acceptance is activated:

- ▶ Remove the handset from the charging cradle.

Switch ringing tone off: 1 Press the Silent display key.

- ▶ The call can be answered for as long as it is shown on the display.

Rejecting calls: 1 Press the Reject display key.



or:

- 1 Press the Hang Up key .

During a call

Changing the volume

This applies to the mode currently in use (hands-free, handset):

- 1 Press the Handsfree key .
- 2 Press the Control key .
- 3 Select the volume required.
- 4 Press the Save display key.

 The setting is automatically saved after about 3 seconds, even if the Save display key is not pressed.

Boost function (extra-loud):

- 1 Press the Boost key on the right-hand side of the handset.

 The greatest volume change with the boost key occurs when the base volume is set to the highest level.

 The boost setting only applies for the duration of the call.

Switching handsfree calling on/off

You can make calls via the speaker and microphone of the handsfree system.

To switch the handsfree function on or off during a call:

- 1 Press the Handsfree key .
- ▶ When the handsfree function is switched on, the handsfree key  lights up.

Ending a call

- 1 Press the Hang Up key .

Internal calls



Several handsets are registered to the base.

- 1 Press the **INT** display key.
- ▶ The list of handsets opens, your own handset is marked with <.
- 2 Select the desired handset or **Call All** (collective call).
- 3 Press the Call key .

Provider-specific functions (Network services)

Network services depend on the network (analog landline or Internet telephony) and the network provider (service provider or telephone system) and may have to be ordered from the latter.

You can find a description of the features on the Internet pages or in the branches of your network provider.

In case of doubt, contact your mobile phone provider.



The commissioning of network services may incur **additional costs**. Check with your network provider.

A distinction is made between two groups of network services:

- Network services that are activated in idle status for the following call or all subsequent calls (e.g. "Call anonymously"). These are activated/deactivated via the **Select Services** menu to activate/deactivate them.
- Network services that are activated during an external call (e.g. "consultation call", "toggle with two call partners", "set up conferences"). These are made available during an external call as an option or via a display key.



A code is sent to the telephone network to switch features on/off or activate/deactivate them.

- ▶ After a confirmation tone from the telephone network, press the hang-up key .

It is not possible to reprogram the network services.

Switch network provider

1 Press the Control key  to open the menu.

2 Press the following keys in succession:

3 Finally, press the key for the network provider:

Select Belgacom (network provider 1): ▶ 

Select Telenet (network provider 2): ▶ 

Phone number transmission

When a call is received, the caller's telephone number is transmitted (CLI = Calling Line Identification) and can be shown on the called party's display (CLIP = CLI Presentation). If the phone number is suppressed, it is not displayed to the called party. The call is anonymous (CLIR = CLI Restriction).

Phone number display for incoming calls

For call number transmission

The caller's number is shown on the display. If the caller's number is stored in the phone book, the name is displayed.

No call number transfer



The following is displayed instead of the name and number:

- **External call:** No number is transmitted.
- **Withheld:** Caller suppresses caller ID transmission.
- **Unavailable:** Caller has not ordered the number transfer.



Phone number transmission for outgoing calls

Activating/deactivating number transfer for all calls

The setting applies to all registered handsets.

- 1 Press the Control key  to open the menu.
- 2 Select **Select Services**.
- 3 Confirm the selection using the display key **OK**.
- 4 Select **All Calls anon..**
- 5 Press the display key **Edit**  = activated/deactivated).
- ▶ You have deactivated caller ID for all outgoing calls.

Switching off phone number transmission for the current call

- 1 Press the Control key  to open the menu.
- 2 Select **Select Services**.
- 3 Confirm the selection using the display key **OK**.
- 4 Select **Next Call anon..**
- 5 Press the **OK** display key.
- 6 Enter the phone number using the keypad .

- 7 Press the **Dial display** key.
 - ▶ The connection is established without transmitting the phone number.

CNIP (Calling Name Identification Presentation)

In addition to the number, the registered name and any other information about the caller are displayed. If the number is saved in the phone book, the name of the phone book entry is displayed instead of the number.

Call waiting tone for an external call

During an **external** call, a call waiting tone signals another external caller. When the phone number is transmitted, the number or name of the caller is displayed.

Reject call waiting:

- 1 Press the **Options** display key.
- 2 Select **Reject Waiting Call**.
- 3 Press the **OK** display key.
 - ▶ The caller hears the busy tone.

Taking a call which is waiting:

- 1 Press the **Accept** display key.

Once you have accepted the waiting call, you can switch between the two callers or speak to both at the same time.

Switching call waiting on/off

- 1 Press the Control key  to open the menu.
- 2 Select **Select Services**.
- 3 Confirm the selection using the **OK** display key.
- 4 Select **Call Waiting**.
- 5 Press the **OK** display key.

Switch on/off: 1 Select the status: **On** or **Off**.

Activate: 1 Press the **Send** display key.

Call waiting is switched on or off for all registered handsets.

Recalling

When busy/no reply



If a call partner is not available, you can initiate a recall

- **If busy:** Callback as soon as the person called has ended the connection.
- **In case of non-registration:** Callback as soon as the person called is back on the phone.

Initiate a recall

- 1 Press the **Options** display key.
- 2 Select **Ringback**.
- 3 Press the **OK** display key.
- 4 Press the **Hang Up** key .

Delete recall prematurely

- 1 Press the **Control** key  to open the menu.
- 2 Select **Select Services**.
- 3 Confirm the selection using the **OK** display key.
- 4 Select **Ringback off**.
- 5 Press the **OK** display key.
 - ▶ You will receive a confirmation from the telephone network.
- 6 Press the **Hang Up** key .



Only one callback can be active. Activating a callback automatically deletes any active callback.

The callback can only be accepted on the handset that has activated the callback.

If the callback is signaled before you can delete it:

- 1 Press the **Hang Up** key .

Call forwarding

With call forwarding, calls are forwarded to another connection.

- 1 Press the **Control** key  to open the menu.
- 2 Select **Select Services**.
- 3 Confirm the selection using the **OK** display key.
- 4 Select **Call Divert**.

- 5 Press the **OK** display key.
- 6 Select one of the following options.

Switch call forwarding on/off: 1 Select the status: **On** or **Off**.

Enter number to forward calls to: 1 Select **To Phone Number**.
2 Enter the phone number using the keypad .

Set time for forwarding: 1 Select **When**.
2 Select the time for forwarding:
All Calls: Calls are forwarded immediately
No Answer: Calls are forwarded if no one picks up after several rings.
When Busy: Calls are forwarded if the line is busy.

Activate: 1 Press the **Send** display key.

A connection to the telephone network is established and a confirmation is sent from the telephone network.

- 1 Press the **Hang Up** key .



Additional costs may be incurred for call forwarding. Check with your network provider.

Calls involving three callers

Queries

Call a second, external subscriber during an external call. The first call is put on hold.

- 1 Press the **Options** display key.
 - 2 Press the **Consultation** display key.
 - 3 Enter the number of the second subscriber using the keypad .
- The previous call is put on hold and the second subscriber is called.

If subscriber called does not answer:

- 1 Press the **End** display key.

End query

- 1 Press the **Options** display key.

- 2 Select **End Active Call**.
- 3 Press the **OK** display key.
 - ▶ The connection to the first call partner is reactivated.



or

- 1 Press the Hang Up key .
- ▶ A callback from the first call partner is initiated.

Brokering

Switch back and forth between two conversations. The other conversation is put on hold.

Call a second person during an external call (consultation call) or accept a call waiting caller.

- ▶ The display shows the phone numbers or names of the two call callers, the current call partner is marked with .
- 1 Use the Control key  to switch back and forth between the subscribers.

End currently active call

- 1 Press the **Options** display key.
- 2 Select **End Active Call**.
- 3 Press the **OK** display key.
 - ▶ The connection to the other party is reactivated.

or

- 1 Press the Hang Up key .
- ▶ A callback from the other party is initiated.

Conference

Talk to two participants at the same time.

Call a second person during an external call (consultation call) or accept a call waiting caller.

- Conference:
- 1 Press the **Options** display key.
 - 2 Press the **Conference** display key.
 - ▶ All conversation partners can hear each other and talk to each other.

- Return to brokering:
- 1 Press the **Options** display key.
 - 2 Press the **End Conference** display key.
 - ▶ You are reconnected to the caller who initiated the conference.



- End the call with both participants:
- 1 Press the Hang Up key .

Each call partner can end their participation in the conference by pressing the Hang Up key  or hanging up the receiver.

Call lists

Call lists

The telephone saves the last numbers called via the base unit in lists. The following call lists are available:

Redial List:	Last dialed numbers.
All calls:	All outgoing, received and missed calls.
Accepted calls:	Calls that have been answered.
Missed calls:	Calls that were not answered If there are missed calls that have not yet been seen, the Message key  flashes. The display shows the symbol  and the number of new entries.



If the call list is full, a new entry overwrites the oldest one.

Editing the call list on the handset

Opening a call list

- 1 Press the Control key  to open the menu.
- 2 Select **Call Lists**.
- 3 Confirm the selection using the **OK** display key.
- 4 Select the list required.
- 5 Press the **OK** display key.
 - ▶ You have opened the required call list.

Information about the calls

- Icon for the call type:
 -  Missed calls
 -  Answered calls
 -  Outgoing calls
- Name of the caller, if the phone number is saved.
- Phone number if no name is available.
- Time and date of the call.

Show more information about an entry:

- 1 Press the Control key  to open the menu.
- 2 Select **Call Lists**.
- 3 Confirm the selection using the **OK** display key.
- 4 Select the list required.
- 5 Press the **OK** display key.
- 6 Select the entry required.
- 7 Press the **View** display key.

Edit call list

- 1 Press the Control key  to open the menu.
- 2 Select **Call Lists**.
- 3 Confirm the selection using the **OK** display key.
- 4 Select the list required.
- 5 Press the **OK** display key.
- 6 Select the entry required.
- 7 Press the **Options** display key.

Transferring a phone number to a phone book

You can add the phone number as a new contact in the central telephone book of the base unit.

- 1 Select **Copy to Directory**.
- 2 Press the **OK** display key.

Deleting entries:

- Delete one entry:
- 1 Select **Delete Entry**.
 - 2 Press the **OK** display key.

- Delete all entries:
- 1 Select **Delete List**.
 - 2 Press the **OK** display key.
 - 3 Confirm the selection using the **Yes** display key.

Phone books

Contacts in the phone book

Opening the phone book

- ▶ Press the Control key .





The entries are sorted alphabetically by surname by default. You can change the sorting arrangement.

Creating a new entry

An entry contains the first name and/or surname and up to three phone numbers.



You can assign a separate ringtone for each contact. This ringtone is played as soon as you receive a call from the contact.

- 1 Press the Control key .
- 2 Select <New Entry>.
- 3 Press the OK display key.
- 4 Use the Control key to move between the input fields:
First Name, Surname, Home Number, Mobile Number, Office Number
- 5 Press the Control key .
- 6 Select the required **Caller Melody (VIP)**.
- 7 Press the display key **Select** ( = activated deactivated).
- 8 Press the **Save** display key.



You must enter at least one phone number.

If an entry does not contain a name, the first phone number entered is saved and displayed as the name instead.



If a **Caller Melody (VIP)** is assigned, the entry in the phone book is supplemented with the **VIP** symbol.

Defining the order of the phone book entries



At least 1 telephone book entry is available.

Phone book entries can be sorted by first or last name. The sorting also affects the search results.



- 1 Press the Control key .
- 2 Press the **Options** display key.
- 3 Select **Sort by First Name** or **Sort by Surname**.
- 4 Press the **OK** display key.
 - ▶ You have changed the sorting arrangement.

If an entry does not contain a name, the default phone number is transferred to the last name field. These entries are placed at the top of the list, regardless of how they are sorted.

The sorting sequence is as follows:

Spaces | Digits (0-9) | Letters (alphabetical) | Remaining characters

Search for contact

- 1 Press the Control key .
 - 2 Use the Control key to navigate to  the required character.
- or:
- 1 Enter the first letter of the name using the keypad .
 - ▶ If entries are found that match the entry, they are displayed.
 - 2 Select the contact required.



If the phone book does not find an entry under the letter entered, the next entry is displayed.

Editing contact details

- 1 Press the Control key .
- 2 Select the contact required.
- 3 Press the **Options** display key.
- 4 Select **Edit Entry**.
- 5 Press the **OK** display key.
- 6 Adapt the entry as desired.
- 7 Press the **Save** display key.

Deleting a contact

- 1 Press the Control key .
- 2 Select the contact required.
- 3 Press the **Options** display key.

- Delete one entry:
- 1 Select **Delete Entry**.
 - 2 Press the **OK** display key.

- Delete all entries:
- 1 Select **Delete List**.
 - 2 Press the **OK** display key.
 - 3 Confirm the selection using the **Yes** display key.

Displaying the number of free entries in the phone book

- 1 Press the Control key .
 - 2 Press the **Options** display key.
 - 3 Select **Available Memory**.
 - 4 Press the **OK** display key.
- ▶ The number of entries available is displayed.



Answering machine and announcements

Activating/Deactivating the answering machine





A description of how to operate the answering machine on the base unit can be found in the overview.

Activating the answering machine via the handset:

- 1 Press the Control key  to open the menu.
 - 2 Select **Answering Machine**.
 - 3 Confirm the selection using the OK display key.
 - 4 Select **Activation**.
 - 5 Press the Edit display key.
 - 6 Select **On** or **Off**.
 - 7 Press the display key **Select** ( = activated deactivated).
- ▶ You have activated the answering machine.
-

Setting the network answering machine

- 1 Press the Control key  to open the menu.
- 2 Select **Answering Machine**.
- 3 Confirm the selection using the OK display key.
- 4 Select **Network Mailbox**.
- 5 Press the OK display key.
- 6 If necessary, adjust the number of the network answering machine using the keypad .
- 7 Press the OK display key.

Operation with the handset

Listening to a voice message:



The answering machine has recorded at least one voice message.

A new voice message is displayed as follows:

- The right-hand display key flashes.
- The display shows the symbol  and the number of new voice messages.

Listening to a voice message:

- 1 Press the right-hand display key.
- 2 Select **Network Mailbox**.
- 3 Press the **OK** display key.
 - ▶ The network answering machine is called.

or:

- 1 Press the Control key  to open the menu.
- 2 Select **Answering Machine**.
- 3 Confirm the selection using the **OK** display key.
- 4 Select **Play Messages**.
- 5 Press the **OK** display key.
- 6 Select **Network Mailbox** or **Answering Machine**.

Network Mailbox: ▶ The network answering machine is called.

Answering Machine:

▶ The selected message is played.



Machine:

- 7 Press the **OK** display key.



The messages are played one after the other, starting with the most recent message.

Actions during playback

- Adjusting the volume:**
- 1 Press the **Options** display key.
 - 2 Select **Volume**.
 - 3 Press the **OK** display key.
 - 4 Select the desired volume using the Control key .
 - 5 Press the **Save** display key.
- The volume setting is automatically saved after 3 seconds.
- Dial a number:**
- 1 Select the corresponding voice message.
 - 2 Press the **Call** key .
 - ▶ The call number is dialed.
- Mark the message as new:**
- 1 Press the **Options** display key.
 - 2 Select **Mark as New**.
 - 3 Press the **OK** display key.
 - ▶ The message is marked as new.
- Copy number in phone book:**
- 1 Press the **Options** display key.
 - 2 Select **Copy to Directory**.
 - 3 Press the **OK** display key.
- Deleting a message:**
- 1 Select the corresponding voice message.
 - 2 Press the **Delete** display key.
- Delete old messages:**
- 1 Press the **Options** display key.
 - 2 Select **Delete Old List**.
 - 3 Press the **OK** display key.
 - ▶ The confirmation prompt **Are you sure you want to delete all old messages?** appears.
 - 4 Press the **Yes** display key.

Retrieving a call from the answering machine

If the **Call Screening** function is activated, you can take a call while the answering machine is recording a call:

- 1 Press the **Call** key .
 - ▶ Recording is canceled. You can speak to the caller.
-



Switching listening in on/off

You can listen in while a message is being recorded via the handset loudspeaker.





If activation of the answering machine is set to **All Calls** there is no call signaling and no listening in. You will not be disturbed.

Switching listening in on/off permanently

- 1 Press the **Control** key  to open the menu.
- 2 Select **Answering Machine**.
- 3 Confirm the selection using the **OK** display key.
- 4 Select **Call Screening**.
- 5 Press the **OK** display key.
- 6 Select **Handset** and/or **Base**.
- 7 Press the display key **Edit**  = activated/deactivated).
- ▶ You have switched the function on.

Switch off listening in for the current recording

- 1 Press the **Silent** display key or the **Hang Up** key .
- 2 Take the call by pressing the **Call** key .

Announcements

Open the Announcements menu

- 1 Press the Control key  to open the menu.
- 2 Select **Answering Machine**.
- 3 Confirm the selection using the **OK** display key.
- 4 Select **Announcements**.
- 5 Press the **OK** display key.
- 6 Select one of the following options.

Recording an announcement



The announcement must be at least 3 seconds long and no longer than 170 seconds so that it can be saved.



Only one announcement can be recorded. If an announcement is recorded again, the current announcement is overwritten.

- 1 Select **Record Phrase**.
- 2 Press the **OK** display key.
 - ▶ The following query appears **For recording press "OK", speak after the tone**.
- 3 Press the **OK** display key.
 - ▶ You can record an announcement after the tone.
- 4 Press the **End** display key.
 - ▶ The recording is saved.
 - ▶ You have recorded an announcement.

Listening to the announcement

You can listen to the announcement you have recorded.

- 1 Select **Play Announcement**.
- 2 Press the **OK** display key.
 - ▶ The current announcement is played.

Deleting the announcement

You can delete the announcement you have recorded. The standard announcement is then active again.

- 1 Select **Delete Announcement**.
- 2 Press the **OK** display key.
- 3 The following query appears **Delete?**
- 4 Press the **Yes** display key.
 - ▶ You have deleted the announcement.



Standard announcements cannot be deleted.

Recording a notification

The phone is supplied with one standard announcement each for recording mode and notification mode. If no personal announcement is available, the corresponding standard announcement is used.

- 1 Select **Record Adv. Msg.**
- 2 Press the **OK** display key.
 - ▶ The confirmation prompt **For recording press "OK", speak after the tone.** appears.
- 3 Press the **OK** display key.
- 4 You can record a notification after the signal tone.
- 5 Press the **End** display key.
 - ▶ The recording is saved.
 - ▶ You have recorded a notification.

Listening to the notification

You can listen to the notification you have recorded.

- 1 Select **Play Advisory Msg.**
- 2 Press the **OK** display key.
 - ▶ The current notification is played.

Deleting the notification

You can delete the notification you have recorded. The standard notification is then activated again.



- 1 Select **Delete Adv. Msg.**
- 2 Press the **OK** display key.
 - ▶ The confirmation prompt **Delete?** appears.
- 3 Press the **Yes** display key.
 - ▶ You have deleted the notification.



The standard notifications cannot be deleted.

Recordings

Changing the answering machine mode

- 1 Press the Control key  to open the menu.
 - 2 Select **Answering Machine**.
 - 3 Confirm the selection using the **OK** display key.
 - 4 Select **Answer & Record**.
 - 5 Press the display key **Edit** ( = activated deactivated).
 - 6 Select the mode for the answering machine:
Answer & Record, Answer only, Alternating
 - 7 Press the display key **Select** ( = activated deactivated).
-

Changing the recording parameters

- 1 Press the Control key  to open the menu.
- 2 Select **Answering Machine**.
- 3 Confirm the selection using the **OK** display key.
- 4 Select **Recordings**.
- 5 Press the **OK** display key.

6 Select one of the following options:

- Length:**
- 1 Select **Length**.
 - 2 Press the **OK** display key.
 - 3 Select the settings required.
 - 4 Press the display key **Select** (☉ = activated deactivated).
- Quality:**
- 1 Select **Quality**.
 - 2 Press the **OK** display key.
 - 3 Select the settings required.
 - 4 Press the display key **Select** (☉ = activated deactivated).
- Call acceptance:**
- 1 Select **Ring Delay**.
 - 2 Press the **OK** display key.
 - 3 Select the settings required.
 - 4 Press the display key **Select** (☉ = activated deactivated).

Changing the language for voice guidance and standard announcement

- 1 Press the Control key  to open the menu.
 - 2 Select **Answering Machine**.
 - 3 Confirm the selection using the **OK** display key.
 - 4 Select **Language**.
 - 5 Press the **OK** display key.
 - 6 Select the required language.
 - 7 Press the **OK** display key.
- ▶ You have changed the language for the voice guidance and the standard announcement.

Further functions

Add more devices

For freedom of movement when making calls, you can register up to 6 DECT cordless handsets on an EASY 500 and EASY 500A.

Registering the handset





Registration must be completed on **both** the base station as well as the handset.

It must be completed on both **within 60 seconds**.

If the handset is not registered on any base unit:

- 1 Press the **Register** display key.

If the handset is already registered on a base unit:



- 1 Press the Control key  to open the menu.
- 2 Select **Settings**.
- 3 Confirm the selection using the **OK** display key.
- 4 Select **Registration**.
- 5 Press the **OK** display key.
- 6 Select **Register Handset** or **Legacy Registration**.
- 7 Press the **OK** display key.
 - ▶ The handset searches for a base unit ready for registration.
- 8 Enter the system PIN using the keypad .
- 9 Press the **OK** display key.
 - ▶ You have registered the handset.

After successful registration, the handset switches to standby mode. The display shows the internal number or the name of the handset if more than one handset is registered. Otherwise, repeat the process.

Deregistering a handset (logging off):

- 1 Press the Control key  to open the menu.
- 2 Select **Settings**.
- 3 Confirm the selection using the **OK** display key.
- 4 Select **Registration**.
- 5 Press the **OK** display key.
- 6 Select **De-register Handset**.
- 7 Press the **OK** display key.
 - ▶ The handset in use is selected.
- 8 If necessary, select a different handset.
- 9 Press the **OK** display key.
- 10 Confirm the prompt by selecting **Yes**.
 - ▶ You have deregistered the handset.

Changing the handset name

- 1 Press the **INT** display key.
 - ▶ The list of handsets opens, your own handset is marked with <.
- 2 Select the desired handset.
- 3 Press the **Options** display key.
- 4 Select **Rename**.
- 5 Press the **OK** display key.
- 6 Delete the current name using the display button .
- 7 Enter the name using the keypad .
- 8 Press the **OK** display key.
 - ▶ You have changed the handset name.

Searching for a handset (paging)

- 1 Press the Log in/Paging button briefly on the base unit.
 - ▶ All handsets ring simultaneously (paging).



Ending a search

- 1 Press the Log in/Paging button briefly on the base unit.
or
- 1 Press the Call key  on the handset.
or
- 1 Press the **Silent** display key.

Room monitoring

- 1 Press the Control key  to open the menu.
- 2 Select **Safety**.
- 3 Confirm the selection using the **OK** display key.
- 4 Select **Room Monitor**.
- 5 Press the **OK** display key.
- 6 Select one of the following options:

- Activate room monitoring:
- 1 Select **Activation**.
 - 2 Press the display key **Edit** ( = activated deactivated).
 - ▶ You have activated room monitoring.

- Send Alarm to:
- 1 Select **Send Alarm to**.
 - 2 Press the **OK** display key.
 - 3 Select **Internal** or **External**.
 - 4 Press the display key **Select** ( = activated deactivated).
 - 5 Enter the phone number using the keypad .



- Two Way Talk:
- 1 Select **Two Way Talk**.
 - 2 Press the display key **Edit** ( = activated deactivated).
 - ▶ You have activated the 2-way call.

- Set sensitivity:
- 1 Select **Sensitivity**.
 - 2 Press the **OK** display key.
 - 3 Select **High** or **Low**.
 - 4 Press the display key **Select** ( = activated deactivated).

ECO DECT

When supplied, the device is set to maximum range. This ensures an optimum connection between the handset and base station. When Standby mode is active, the handset does not transmit, it is radiation-free. Only the base station provides contact with the handset via low radio signals. During a call, the transmission power automatically adjusts to the distance between the base and the handset. The smaller the distance to the base, the lower the radiation.



Reducing radiation by up to 80%

- 1 Press the Control key  to open the menu.
- 2 Select **Settings**.
- 3 Confirm the selection using the **OK** display key.
- 4 Select **ECO DECT**.
- 5 Press the **OK** display key.
- 6 Select **Maximum Range**.
- 7 Press the display key **Edit** ( = activated deactivated).



This setting also reduces the range. It is not possible to use a repeater to increase the range.

Deactivating radiation in Standby mode

- 1 Press the Control key  to open the menu.
- 2 Select **Settings**.
- 3 Confirm the selection using the **OK** display key.
- 4 Select **No Radiation**.
- 5 Press the display key **Edit** ( = activated deactivated).



To take advantage of the **No Radiation** setting, all registered handsets must support this feature.

If the setting **No Radiation** is activated and a handset that does not support this feature is registered on the base, it is automatically deactivated. **No Radiation** is automatically deactivated.

As soon as this handset is logged off again, it is **No Radiation** is automatically reactivated.

The wireless connection is only established automatically for incoming or outgoing calls. This delays the connection setup by approx. 2 seconds.

In order for a handset to quickly establish a radio connection to the base when an incoming call is received, it must "listen" to the base more frequently, i.e. scan the surroundings. This increases power consumption and therefore reduces the handset's standby and talk time.

If **No Radiation** is activated, there is no range display/range alarm on the handset. You can check the availability by trying to establish a connection.

- 1 Press and hold down the Call key .
- ▶ The dialing tone sounds.



Protection from unwanted calls

Call security

- 1 Press the Control key  to open the menu.
- 2 Select **Safety**.
- 3 Confirm the selection using the **OK** display key.
- 4 Select **Protect Incoming Calls**.
- 5 Press the **OK** display key.

Blocklists

- 1 Select **Blocklist**.
- 2 Press the **Edit** display key.



Blocked numbers:	<ol style="list-style-type: none"> 1 Select Blocked Numbers. 2 Press the OK display key. 3 Press the New display key. 4 Enter the phone number using the keypad . 5 Press the Save display key.
Protection mode:	<ol style="list-style-type: none"> 1 Select Protection Mode. 2 Press the OK display key. 3 Select one of the following options: No Protection, Silent Call, Block Call 4 Press the display key Select ( = activated/deactivated).

Anonymous calls

- 1 Select **Anonymous Calls**.
- 2 Press the **Edit** display key.
- 3 Select one of the following options:
No Protection, Silent Call, Block Call
- 4 Press the display key **Select** ( = activated/deactivated).

Blocking anonymous calls



If activated, the handset does not ring for calls without caller ID.

- 1 Press the **Control** key  to open the menu.
- 2 Select **Safety**.
- 3 Confirm the selection using the **OK** display key.
- 4 Select **Anon. Calls Silent**.
- 5 Press the display key **Edit** ( = activated/deactivated).

Settings on the handset

Setting the date and time

The date and time must be set so that the date and time can be correctly assigned to incoming calls. The date and time are synchronized between the base unit and handset.



- 1 Press the Control key  to open the menu.
 - 2 Select **Settings**.
 - 3 Confirm the selection using the display button **OK**.
 - 4 Select **Date/Time**.
 - 5 Press the **OK** display key.
 - 6 Enter the date using the keypad .
 - 7 Enter the time using the keypad .
 - 8 Press the **Save** display key.
- ▶ You have set the date and time.







The automatic changeover from summer to winter time is calculated from the date including year and time.

The time can be updated by selecting the network time during CLIP transmission (without year information).



Displaying the language

- 1 Press the Control key  to open the menu.
 - 2 Select **Settings**.
 - 3 Confirm the selection using the display button **OK**.
 - 4 Select **Language**.
 - 5 Press the **OK** display key.
 - 6 Select the required language.
 - 7 Press the display key **Select**  = activated/deactivated).
- ▶ You have defined the display language.

If an incomprehensible language is set:

- 1 Press the Control key  to open the menu.
- 2 Firstly, press the key .
- 3 Press the key  a second time.
- 4 Select the required language.
- 5 Press the display key **Select**  = activated/deactivated).

Country

- 1 Press the Control key  to open the menu.
 - 2 Select **Settings**.
 - 3 Confirm the selection using the display button **OK**.
 - 4 Select **Country**.
 - 5 Press the **OK** display key.
 - 6 Select the desired country.
 - 7 Press the display key **Select** ( = activated/deactivated).
- ▶ You have changed the country setting.

Boost key

During a call, you can set the volume for the handset or loudspeaker to a significantly higher level (boost).

-  The greatest volume change with the Boost key occurs when the base volume is set to the highest level.

Switching the boost on/off:

- 1 Press the Boost key on the right-hand side of the handset.
- ▶ A symbol in the display shows the status:

Switched on:



Switched off:



The boost setting only applies for the duration of the call.



This setting can cause damage to the wellbeing of people with normal hearing and is intended for people with hearing impairment or hearing loss.

Noise from the telephone line can be amplified.

Tones and signals

Handset volume

You can adjust the volume of the handset in stages.

During a call

- 1 Press the **Options** display key.
- 2 Select **Volume**.
- 3 Press the **OK** display key.
- 4 Adjust the volume as required.
- 5 Press the **Save** display key.
 - ▶ The setting is saved.



Without pressing **Save** directly, the setting is automatically saved after approx. 3 seconds.

In Standby mode:

- 1 Press the Control key  to open the menu.
- 2 Select **Audio Settings**.
- 3 Confirm the selection using the display button **OK**.
- 4 Select **Handset Volume**.
- 5 Press the **OK** display key.
- 6 Select the volume required.
- 7 Press the **Save** display key.
 - ▶ You have set the volume.

Handsfree mode volume



You can adjust the volume of the loudspeaker in stages.

- 1 Press the Control key  to open the menu.
- 2 Select **Audio Settings**.
- 3 Confirm the selection using the display button **OK**.
- 4 Select **Handsfree Volume**.
- 5 Press the **OK** display key.
- 6 Select the volume required.
- 7 Press the **Save** display key.
- ▶ You have set the volume.

Handset and handsfree profile

Select the profile for the **handset** and **handsfree mode** to adapt the phone optimally to the surrounding situation. Check for yourself which profile you and the callers are most comfortable with.

- 1 Press the Control key  to open the menu.
- 2 Select **Audio Settings**.
- 3 Confirm the selection using the display button **OK**.
- 4 Select **Acoustic Profiles**.
- 5 Press the **OK** display key.
- 6 Select the profile required:

Earpiece Profiles:	<ol style="list-style-type: none"> 1 Press the OK display key. 2 Select High or Low (delivery status). 3 Press the display key Select ( = activated/deactivated).
Handsfree Profiles:	<ol style="list-style-type: none"> 1 Press the OK display key. 2 Select Profile 1 (delivery status) or Profile 2. 3 Press the display key Select ( = activated/deactivated).

Ringtones



Ringtone volume

You can set the ringtone volume in 5 levels or as a crescendo (increasing volume).

- 1 Press the Control key  to open the menu.
 - 2 Select **Audio Settings**.
 - 3 Confirm the selection using the display button **OK**.
 - 4 Select **Ringtones (Handset)**.
 - 5 Press the **OK** display key.
 - 6 Select **Volume**.
 - 7 Press the **OK** display key.
 - 8 Select **Internal** or **External call**.
 - 9 Press the **OK** display key.
 - 10 Adjust the volume as required.
 - 11 Press the **Save** display key.
- ▶ You have set the volume.

Ringtone melody

You can set different ringtones for internal and external calls.



- 1 Press the Control key  to open the menu.
 - 2 Select **Audio Settings**.
 - 3 Confirm the selection using the display button **OK**.
 - 4 Select **Ringtones (Handset)**.
 - 5 Press the **OK** display key.
 - 6 Select **Melodies**.
 - 7 Press the **OK** display key.
 - 8 Select **Internal** or **External call**.
 - 9 Press the **OK** display key.
 - 10 Select the melody required.
 - 11 Press the display key **Select**  = activated/deactivated).
- ▶ You have adapted the ringtone melody.

Basic ringtone (only Gigaset EASY 500A)

- 1 Press the Control key  to open the menu.
 - 2 Select **Audio Settings**.
 - 3 Confirm the selection using the OK display key.
 - 4 Select **Ringtones (Base)**.
 - 5 Press the OK display key.
 - 6 Select **Melodies**.
 - 7 Press the OK display key.
 - 8 Select the melody required.
 - 9 Press the **Save** display key.
- ▶ You have adapted the ringtone melody.

Notification tones

The handset indicates various activities and statuses acoustically. You can switch these notification tones on/off independently of each other.

- 1 Press the Control key  to open the menu.
- 2 Select **Audio Settings**.
- 3 Confirm the selection using the OK display key.
- 4 Select **Advisory Tones**.
- 5 Press the OK display key.
- 6 Select the contact required.
- 7 Press the display key **Edit**  = activated/deactivated).



Key Tones: The handset generates a tone when a key is pressed.

Confirmation: The handset generates a confirmation/error tone after entries or an alert tone when a new message arrives.

Battery: The handset generates a warning tone when the remaining call time is less than 10 minutes (every 60 seconds).

Out of Range: The handset generates a warning tone when the handset moves out of range of the Base unit.



Waiting melody

- 1 Press the Control key  to open the menu.
- 2 Select **Audio Settings**.
- 3 Confirm the selection using the **OK** display key.
- 4 Select **Music on Hold**.
- 5 Press the display key **Edit** ( = activated/deactivated).

Display

Screensaver

A digital or analog clock is available as a screensaver for the display when in Standby mode.

- 1 Press the Control key  to open the menu.
 - 2 Select **Settings**.
 - 3 Confirm the selection using the **OK** display key.
 - 4 Select **Display**.
 - 5 Press the **OK** display key.
 - 6 Select **Screensaver**.
 - 7 Press the **OK** display key.
 - 8 Select **Activation**.
 - 9 Press the display key **Edit** ( = activated/deactivated).
 - 10 Select **Select**.
 - 11 Press the **OK** display key.
 - 12 Select the screensaver required.
 - 13 Press the display key **Select** ( = activated/deactivated).
- ▶ You have set a screensaver.



The screensaver is activated approximately 10 seconds after the display has switched to Standby mode.

Exit screensaver

- 1 Press the right-hand display key.
- ▶ The display enters Standby mode.



Large font

You can enlarge the font and symbols in call lists and the phone book to make them easier to read. Only one entry is shown in the display and names are abbreviated, if necessary. When dialing, the phone number is displayed with large digits.

- 1 Press the Control key  to open the menu.
 - 2 Select **Settings**.
 - 3 Confirm the selection using the **OK** display key.
 - 4 Select **Display**.
 - 5 Press the **OK** display key.
 - 6 Select **Large Font**.
 - 7 Press the display key **Edit** ( = activated/deactivated).
- ▶ You have enlarged the font.
-

Color scheme

The display can be shown in different color combinations.

- 1 Press the Control key  to open the menu.
 - 2 Select **Settings**.
 - 3 Confirm the selection using the **OK** display key.
 - 4 Select **Display**.
 - 5 Press the **OK** display key.
 - 6 Select **Colour Scheme**.
 - 7 Press the **OK** display key.
 - 8 Select the color scheme required.
 - 9 Press the display key **Select** ( = activated/deactivated).
- ▶ You have adjusted the color scheme.
-

Display illumination

The display backlight is switched off if the handset has not been operated for a while. You can use this function for the situations **In Charger** and **In Talk State** independently of each other.

- 1 Press the Control key  to open the menu.
- 2 Select **Settings**.
- 3 Confirm the selection using the **OK** display key.
- 4 Select **Display**.

- 5 Press the **OK** display key.
- 6 Select **Backlight**.
- 7 Press the **OK** display key.
- 8 Select the operating status in which the lighting should be switched off:
In Charger, In Talk State
- 9 Press the display key **Edit** (☑ = activated/deactivated).
 - ▶ You have changed the setting for the display lighting.



When the display backlight is switched on, the handset's standby time can be considerably reduced.

Telephony

Automatic call acceptance

With automatic call acceptance, the handset takes an incoming call as soon as it is removed from the charging cradle.

- 1 Press the Control key (☐) to open the menu.
- 2 Select **Settings**.
- 3 Confirm the selection using the **OK** display key.
- 4 Select **Telephony**.
- 5 Press the **OK** display key.
- 6 Select **Auto Answer**.
- 7 Press the display key **Edit** (☑ = activated/deactivated).
 - ▶ You have activated automatic call acceptance.



Regardless of the **Auto Answer** setting, the connection is terminated as soon as you place the handset in the charging cradle.

Number for an outside line



- 1 Press the Control key (☐) to open the menu.
- 2 Select **Settings**.
- 3 Confirm the selection using the **OK** display key.
- 4 Select **Telephony**.
- 5 Press the **OK** display key.
- 6 Select **Access Code**.

- 7 Press the **OK** display key.
 - 8 Select **Access external line with**.
 - 9 Enter a prefix using the keypad .
 - 10 Select the case for which the area code should be used.
For: Off, Call Lists, All Calls
 - 11 Press the **Save** display key.
 - ▶ You have entered the number for an outside line.
-

Dialing method

- 1 Press the Control key  to open the menu.
 - 2 Select **Settings**.
 - 3 Confirm the selection using the **OK** display key.
 - 4 Select **Telephony**.
 - 5 Press the **OK** display key.
 - 6 Select **Dialling Mode**.
 - 7 Press the **OK** display key.
 - 8 Select **Tone or Pulse**.
 - 9 Press the display key **Select**  = activated/deactivated).
 - ▶ You have changed the dialing method.
-

Flash times

- 1 Press the Control key  to open the menu.
- 2 Select **Settings**.
- 3 Confirm the selection using the **OK** display key.
- 4 Select **Telephony**.
- 5 Press the **OK** display key.
- 6 Select **Recall**.
- 7 Press the **OK** display key.
- 8 Select the flash timer required.
- 9 Press the display key **Select**  = activated/deactivated).
 - ▶ You have selected the flash time required.

System

Resetting the handset

You can reset individual settings and modifications.



- 1 Press the Control key  to open the menu.
 - 2 Select **Settings**.
 - 3 Confirm the selection using the OK display key.
 - 4 Select **System**.
 - 5 Press the OK display key.
 - 6 Select **Handset Reset**.
 - 7 Press the OK display key.
 - 8 Confirm the prompt by selecting **Yes**.
- ▶ The handset settings are reset.



The following settings are **not** affected by the reset:

- Registration of the handset on the base unit
- Date and time
- Phone book and call list entries



Encryption

- 1 Press the Control key  to open the menu.
 - 2 Select **Settings**.
 - 3 Confirm the selection using the OK display key.
 - 4 Select **System**.
 - 5 Press the OK display key.
 - 6 Select **Encryption**.
 - 7 Press the display key **Edit** ( = activated/deactivated).
- ▶ You have activated encryption.

Changing the system PIN

You can secure the phone's system settings with a PIN. You must enter the system PIN when registering and deregistering a handset or when resetting to the default settings.

Changing the phone's 4-8-digit system PIN (delivery status: 0000):

- 1 Press the Control key  to open the menu.
 - 2 Select **Settings**.
 - 3 Confirm the selection using the OK display key.
 - 4 Select **System**.
 - 5 Press the OK display key.
 - 6 Select **System PIN**.
 - 7 Press the OK display key.
 - 8 Enter the new PIN using the keypad .
 - 9 Press the **Save** display key.
- ▶ You have changed the system PIN.

Resetting the base unit

This function returns the base unit to its Standby state.

- 1 Press the Control key  to open the menu.
- 2 Select **Settings**.
- 3 Confirm the selection using the OK display key.
- 4 Select **System**.
- 5 Press the OK display key.
- 6 Select **Base Reset**.
- 7 Press the OK display key.
- 8 Confirm the prompt by selecting **Yes**.
- 9 The base unit settings are reset.

Resetting the base unit factory settings

If you initiate this function, all settings of your base unit are reset to the default settings (e.g. PIN 0000 again). All registered handsets are deregistered.

- 1 Disconnect the base unit from the power supply.
 - 2 Press and hold the Log in/Paging button on the base unit.
 - 3 Connect the base unit to the power supply.
 - 4 Release the Log in/Paging button.
- ▶ The base unit starts the reset process.



Resetting the base unit takes approx. 30 seconds. The base unit must not be disconnected from the power supply during this period!

Operating aids





Direct dialing keys

You can save important telephone numbers on the three direct dialing keys **A**, **B** and **C**. You dial the number stored by pressing the corresponding direct dialing key.

Assigning a phone number to direct dialing keys



No function is yet assigned to the respective direct dialing keys.

- 1 Press the direct dialing key (**A**, **B** and **C**) to which you want to assign a function.
- 2 Enter the phone number using the keypad .
- 3 Press the Control key .
- 4 Enter the first name using the keypad .
- 5 Press the Control key .
- 6 Enter the surname using the keypad .
- 7 Press the Save display key.



Or dial from the phone book:

- 1 Press the direct dialing key (**A**, **B** and **C**) to which you want to assign a function.
- 2 Press the  display key.
- 3 Select the entry required.
- 4 Press the OK display key.
 - ▶ The phone number, first name and surname are taken from the phone book and can be modified, if necessary.
- 5 Press the Save display key.
 - ▶ You have assigned a phone number to a direct dialing key.





Changing/Deleting the assignment of the direct dialing keys

- 1 Press the Control key  to open the menu.
- 2 Select **Accessibility**.
- 3 Confirm the selection using the OK display key.
- 4 Select **Direct Dial Keys**.
- 5 Confirm the selection using the OK display key.
 - ▶ The current key assignment is displayed, e.g:

SOS

- A: - - - = the  key is not yet assigned
- B: Surname, = the  key is assigned the phone number of the
Rudi subscriber displayed
- C: 12345678 = the  key is assigned the phone number displayed,
the name is not known

Changing an entry

- 1 Select the direct dialing key required.
- 2 Press the OK display key.
- 3 Press the **Options** display key.
- 4 Select **Edit Entry**.
- 5 Press the OK display key.
- 6 Enter the phone number using the keypad .
- 7 Press the Control key .
- 8 Enter the first name using the keypad .
- 9 Press the Control key .
- 10 Enter the surname using the keypad .
- 11 Press the **Save** display key.
 - ▶ You have modified the entry.

Deleting an entry

- 1 Select the direct dialing key required.
- 2 Press the OK display key.
- 3 Press the **Options** display key.
- 4 Select **Delete Entry**.
- 5 Press the OK display key.
 - ▶ You have deleted the entry.

Announcements

People with impaired vision can have buttons, phone numbers and contacts announced.

Key announcement

- 1 Press the Control key  to open the menu.
 - 2 Select **Accessibility**.
 - 3 Confirm the selection using the **OK** display key.
 - 4 Select **Acoustic**.
 - 5 Press the **OK** display key.
 - 6 Select **Talking Dial Keys**.
 - 7 Press the display key **Edit** (= activated/deactivated).
 - ▶ You have activated the key announcement function.
-

Announcement language

- 1 Press the Control key  to open the menu.
- 2 Select **Accessibility**.
- 3 Confirm the selection using the **OK** display key.
- 4 Select **Acoustic**.
- 5 Press the **OK** display key.
- 6 Select **Language Read Aloud**.
- 7 Press the **OK** display key.
- 8 Select the required language.
- 9 Press the display key **Select** (= activated/deactivated).
- ▶ You have set the announcement language.

Number announcement

If the function is activated, the digits entered are announced when the phone number is entered.

- 1 Press the Control key  to open the menu.
 - 2 Select **Accessibility**.
 - 3 Confirm the selection using the OK display key.
 - 4 Select **Acoustic**.
 - 5 Press the OK display key.
 - 6 Select **Caller ID**.
 - 7 Press the display key Edit (= activated/deactivated).
- ▶ You have activated the number announcement.
-

Read out contacts

If the function is activated, the announcement stored for the contact is read out when a phone book entry is selected in the handset phone book and the announcement is played when a call is received.



An announcement is stored for the contact in the handset phone book.

- 1 Press the Control key  to open the menu.
 - 2 Select **Accessibility**.
 - 3 Confirm the selection using the OK display key.
 - 4 Select **Acoustic**.
 - 5 Press the OK display key.
 - 6 Select **Read Aloud Directory**.
 - 7 Press the display key Edit (= activated/deactivated).
- ▶ You have activated the contact announcement.
-

Recording announcements for contacts

You can record your own announcements for approx. 50 entries, which is played back as soon as the number calls.

- 1 Press the Control key  to open the menu.
- 2 Select **Handset Directory**.
- 3 Press the **Options** display key.
- 4 Select **Phrase**.

- 5 Press the **OK** display key.
- 6 Select **Record Phrase**.
- 7 Press the **OK** display key.
- 8 You can record your announcement after a countdown.
- 9 Press the **Save** display key.
- ▶ You have recorded an announcement.



An announcement cannot last longer than 3 seconds. If this time is exceeded, the recording stops and the announcement is saved.

Brightness



- 1 Press the Control key to open the menu.
- 2 Select **Accessibility**.
- 3 Confirm the selection using the **OK** display key.
- 4 Select **Brightness**.
- 5 Press the **OK** display key.
- 6 Select **Handset and/or Base**.
- 7 Press the **OK** display key.

Set the brightness

- 1 Select **Brightness**.
- 2 Press the **OK** display key.
- 3 Set the brightness using the Control key .
- 4 Press the **Save** display key.
- ▶ You have set the brightness.

Set time control

- 1 Select **Time Control**.
 - 2 Press the **OK** display key.
- Activate time control:
- 1 Select **Activation**.
 - 2 Press the display key **Edit** (= activated/deactivated).
 - ▶ You have activated the time control.

- Set brightness:**
- 1 Select **Brightness**.
 - 2 Press the **OK** display key.
 - 3 Set the brightness using the Control key .
 - 4 Press the **Save** display key.
 - 5 You have set the brightness.
- Start the setting:**
- 1 Select **Start**.
 - 2 Press the **OK** display key.
 - 3 Enter the start time using the keypad .
 - 4 Press the **Save** display key.
 - ▶ You have set the start time.
- Set the end:**
- 1 Select **End**.
 - 2 Press the **OK** display key.
 - 3 Enter the end time using the keypad .
 - 4 Press the **Save** display key.
 - ▶ You have set the end time.
- Set automatic deactivation:**
- 1 Select **Automated Deactivation**.
 - 2 Press the display key **Edit** (= activated/deactivated).
 - ▶ You have set the automatic deactivation of the time control.

LED call alert signal

If the function is activated, the signal light at the top of the handset flashes red when an incoming call is received.

- 1 Press the Control key  to open the menu.
- 2 Select **Accessibility**.
- 3 Confirm the selection using the **OK** display key.
- 4 Select **Signal Call via LED**.
- 5 Press the display key **Edit** (= activated/deactivated).
 - ▶ You have activated the LED call alert signal.

Serious caller

If this function is activated, all calls from contacts entered in the phone book are visually highlighted by a highly visible green display background. Other calls are displayed with a black or white background depending on the selected color scheme.

- 1 Press the Control key  to open the menu.
 - 2 Select **Safety**.
 - 3 Confirm the selection using the OK display key.
 - 4 Select **Trusted Caller**.
 - 5 Press the display key Edit (= activated/deactivated).
- ▶ You have activated the function.

Simple menu

Decide for yourself which functions are displayed in the menu. You can show or hide the following submenus:

- Handset Directory
- Call Lists
- Answering Machine
- Audio Settings
- Accessibility
- Safety
- Help Call Settings
- Settings
- Select Services

Activating the simple menu

- 1 Press the Control key  to open the menu.
 - 2 Select **Accessibility**.
 - 3 Confirm the selection using the OK display key.
 - 4 Select **Simple Menu**.
 - 5 Press the OK display key.
 - 6 Select **Simple Menu**.
 - 7 Press the display key Edit (= activated/deactivated).
- ▶ You have activated the simple menu.

Configuring the menu view

- 1 Press the Control key  to open the menu.
 - 2 Select **Accessibility**.
 - 3 Confirm the selection using the OK display key.
 - 4 Select **Simple Menu**.
 - 5 Press the OK display key.
 - 6 Select **Menu List**.
 - 7 Press the OK display key.
 - 8 Use the Control key to select the desired option.
 - 9 Press the display key Edit (= activated/deactivated).
- ▶ You have configured the menu view.



If you **Accessibility** is hidden, the menu displays **Simple Menu** instead. Therefore, you can change your settings for the menu at any time.

Allowing the handset to be switched off



- 1 Press the Control key  to open the menu.
- 2 Select **Accessibility**.
- 3 Confirm the selection using the OK display key.
- 4 Select **Switch off Handset**.
- 5 Press the display key Edit (= activated/deactivated).

Direct extension for emergencies (for EASY 500 and EASY 500HX on one router)



Define up to 15 phone numbers that are automatically put through when a call is received. You can speak to the caller via the handsfree system on your handset without having to accept the call.

Define an extension PIN for the extension function. The caller needs this for the direct extension. The extension PIN must also be entered when switching the function on and off.

Activating/Deactivating the extension number

- 1 Press the Control key  to open the menu.
 - 2 Select **Safety**.
 - 3 Confirm the selection using the OK display key.
 - 4 Select **Supervision Call**.
 - 5 Press the OK display key.
 - 6 Select **Settings**.
 - 7 Press the OK display key.
 - 8 Enter the extension PIN using the keypad .
 - 9 Select **Activation**.
 - 10 Press the display key **Edit** ( = activated/deactivated).
- ▶ You have activated the extension for emergencies.

Setting a delay



- 1 Press the Control key  to open the menu.
 - 2 Select **Safety**.
 - 3 Confirm the selection using the OK display key.
 - 4 Select **Supervision Call**.
 - 5 Press the OK display key.
 - 6 Select **Settings**.
 - 7 Press the OK display key.
 - 8 Enter the extension PIN using the keypad .
 - 9 Select **Delay**.
 - 10 Press the OK display key.
 - 11 Select the delay required.
 - 12 Press the display key **Select** ( = activated/deactivated).
- ▶ You have set the delay.





If the answering machine is switched on, the delay time must be shorter than the time set for the answering machine **Auto Answer** of the answering machine. As soon as the answering machine accepts a call, a direct extension is no longer possible.

Example: A delay time of 25 seconds with automatic call acceptance of the answering machine of 30 seconds makes sense.

Changing the extension PIN

- 1 Press the Control key  to open the menu.
 - 2 Select **Safety**.
 - 3 Confirm the selection using the OK display key.
 - 4 Select **Supervision Call**.
 - 5 Press the OK display key.
 - 6 Select **Settings**.
 - 7 Press the OK display key.
 - 8 Enter the extension PIN using the keypad .
 - 9 Select **PIN**.
 - 10 Press the OK display key.
 - 11 Enter the new extension PIN using the keypad .
 - 12 Press the OK display key.
- ▶ You have changed the extension PIN.

Entering/Editing/Deleting phone numbers

- 1 Press the Control key  to open the menu.
- 2 Select **Safety**.
- 3 Confirm the selection using the OK display key.
- 4 Select **Supervision Call**.
- 5 Press the OK display key.
- 6 Select **Allowlist**.
- 7 Press the OK display key.
- 8 Select one of the following options:
 - 1 Select **<New Entry>**.
 - 2 Press the OK display key.
 - 3 Enter the phone number using the keypad .
 - 4 Press the **Save** display key.

▶ You have created a new entry.
- Change the entry:
 - 1 Select the entry required.
 - 2 Press the **Edit** display key.
 - 3 Edit the entry as required.
 - 4 Press the **Save** display key.

▶ You have modified the entry.

- Delete an entry:
- 1 Select the entry required.
 - 2 Press the **Edit** display key.
 - 3 Confirm the selection using the **Yes** display key.
 - ▶ You have deleted the entry.

Procedure



Supervision Call is activated, an extension PIN is set. The caller is entered as an authorized caller and knows the current extension PIN.

- 1 The caller dials your number. The caller is prompted to enter the extension PIN in an announcement.
- 2 The caller enters the extension PIN.
 - Extension PIN incorrect: ▶ The call is canceled immediately.
 - Extension PIN correct: ▶ The call is put through. The handsfree function of the handset is activated. The display shows a red microphone symbol.
 - ▶ Both participants can now speak to each other via the hands-free system.



The call is automatically ended after approx. 3 minutes if one of the participants does not hang up. The caller may have to call again.





For security reasons, the phone reacts sensitively when interpreting the extension PIN. Transmission fluctuations in the telephone network can result in the PIN not being recognized. If the call is canceled, try again.

Direct extension for emergencies (for EASY 500A)

Define up to 15 phone numbers that are automatically put through when a call is received. You can speak to the caller via the handsfree system on your handset without having to accept the call.

For the direct dial function, you must set the system PIN to a value other than 0000. The caller needs this for the direct extension. The system PIN must also be entered when switching the function on and off.

Activating/Deactivating the extension number

- 1 Press the Control key  to open the menu.
 - 2 Select **Safety**.
 - 3 Confirm the selection using the OK display key.
 - 4 Select **Supervision Call**.
 - 5 Press the OK display key.
 - 6 Select **Handset**.
 - 7 Press the OK display key.
 - 8 Enter the system PIN using the keypad .
 - 9 Press the OK display key.
 - 10 Select the handset that is to accept the extension.
 - 11 Press the display key **Select** ( = activated/deactivated).
 - 12 Select **Activation**.
 - 13 Press the display key **Edit** ( = activated/deactivated).
- ▶ You have activated the extension for emergencies.

Procedure



Supervision Call is activated, a system PIN is set and is not equal to 0000. The caller is entered as an authorized caller and knows the current system PIN.



The call is automatically ended after approx. 3 minutes if one of the participants does not hang up. The caller may have to call again.

For security reasons, the phone reacts sensitively when interpreting the system PIN. Transmission fluctuations in the telephone network can result in the PIN not being recognized. If the call is canceled, try again.

The answering machine is switched on:

- 1 The caller dials your number.
- 2 The caller must press the  button when the answering machine announcement is heard.

3 The caller enters the system PIN.

PIN incorrect: ▶ The call is canceled immediately.

PIN correct: ▶ The call is put through. The handsfree function of the handset is activated. A warning tone sounds in the called party's handset.

▶ Both participants can now speak to each other via the handsfree system.

The answering machine is switched off:

1 The caller dials your number.

2 The caller waits until the announcement "Dial option" prompts the caller to press .

3 The caller is prompted to enter the system pin.

4 The caller enters the system PIN.

PIN incorrect: ▶ The call is canceled immediately.

PIN correct: ▶ The call is put through. The handsfree function of the handset is activated. A warning tone sounds in the called party's handset.

▶ Both participants can now speak to each other via the handsfree system.

Appendix

Customer service & help

Do you have any questions?

Quick help and information can be found in these operating instructions.

Further information on the topics

- Products
- Documents (Documentation)
- Interop (interoperability)
- Firmware
- FAQ
- Support

is available at gigaset.com/service or by scanning the QR code to access the online support page directly:



Manufacturer's information

Approval

This device is intended for an analog telephone connection.

Country-specific features are taken into account.

Gigaset Technologies GmbH hereby declares that the following types of radio equipment comply with Directive 2014/53/EU:

Gigaset EASY 500 / Gigaset EASY 500 A / Gigaset EASY 500 HX

The full text of the EU Declaration of Conformity is available at the following web address www.gigaset.com/docs.

If this product is also imported into the UK:

Gigaset Technologies GmbH hereby declares that the following types of radio equipment comply with the Radio Equipment Regulations 2017: Gigaset EASY 500 / Gigaset EASY 500 A / Gigaset EASY 500 HX

The full text of the UK Declaration of Conformity is available at the following internet address: www.gigaset.com/docs.

In some cases, this declaration may be included in the "International Declarations of Conformity" or "European Declarations of Conformity" files.

Therefore, please read these files too.

Guarantee Certificate

Unless otherwise specified, the guarantor (hereinafter referred to as "Gigaset Technologies") grants the consumer (customer) a durability warranty under the following conditions (warranty conditions), without prejudice to the consumer's statutory rights relating to defects. The customer's warranty rights are not limited by this warranty. Warranty rights can be asserted free of charge. This warranty represents an obligation on the part of the guarantor in addition to the statutory warranty rights that can be asserted free of charge for defect claims.

Warranty conditions:

- In the case of new devices (telephones, smartphones) and their components exhibiting defects within 24 months of purchase, Gigaset Technologies shall, at its own option and free of charge, either replace the device with another device reflecting the current state of the art, or repair the said device. This durability warranty applies for 12 months from the date of purchase for parts subject to wear (all moving parts that can be replaced by the customer itself, e.g. spare parts, batteries, keyboards, housing).
- This warranty does not apply in the event a defect to devices is attributable to improper treatment and/or a failure to follow the operating guides.
- This warranty does not cover any services provided by the appointed dealer or by the customer himself (e.g. installation, configuration, software downloads). Manuals and, where applicable, accompanying software on a separate data carrier are also excluded from the warranty.

- Proof of purchase plus date of purchase are required as evidence of a valid warranty. Warranty claims must be asserted within two (2) months of the awareness of a warranty event.
- Replaced devices or their components returned to Gigaset Technologies during the course of an exchange are transferred to the ownership of Gigaset Technologies.
- This warranty applies to new devices acquired within the European Union. These will be exchanged free of charge for a technologically current device or repaired by Gigaset Technologies. The warrantor is Gigaset Technologies GmbH, Frankenstraße 2, D-46395 Bocholt.
- No further or different claims arising from this manufacturer's warranty will be accepted. Gigaset Technologies accepts no liability for operational interruptions, loss of profit and loss of data, software additionally installed by the customer or other information. The customer is responsible for safeguarding these. The liability disclaimer does not apply if liability is mandatory, for example under the Product Liability Act, in cases of wilful intent, gross negligence, injury to life, limb and health or breach of material contractual obligations. Claims for damages in respect of breach of material contractual obligations are however limited to foreseeable losses typical for the contract, unless liability is as a result of wilful intent, gross negligence, injury to life, limb and health or under the Product Liability Act.
- Successful assertion of a warranty claim does not extend the term of the warranty.
- Unless there is a warranty event, Gigaset Technologies reserves the right to charge the customer for an exchange or repair. Gigaset Technologies will inform the customer of this in advance.
- Any change to the rules governing burden of proof to the detriment of the customer is not connected with the above rules.
- Federal German law applies to this warranty, to the exclusion of the United Nations Convention on Contracts for the International Sale of Goods (CISG). This choice of law does not deprive the consumer of the protection he/she would have been granted under provisions that cannot be derogated from by agreement, according to the law of the country in which he/she has her habitual residence ("favourability principle").

Please contact the warrantor's customer services to redeem and assert this warranty. You can find the relevant telephone number in our Service Portal at www.gigaset.com/service.

Exemption from liability

The display of the handset consists of pixels. Each pixel consists of three sub-pixels (red, green, blue).

It may be the case that a sub-pixel is missing or has a color deviation.

The right to assert a claim through the terms of guarantee exists if the maximum number of permitted pixel errors is exceeded.

Description	Max. number of permitted pixel errors
Colored glowing sub-pixels	1
Dark sub-pixels	1
Total number of colored and dark sub-pixels	1



Signs of wear on the display and housing are excluded from the guarantee.

Data protection

At Gigaset, we take the protection of our customers' data very seriously. This is precisely why we ensure that all our products are developed according to the principle of "Privacy by Design". All the data we collect is used to make our products as good as possible. We ensure that your data is protected and only used for the purpose of providing you with a service or product. We know which route your data takes within the company and ensure that it is secure, protected and compliant with data protection regulations.

The full text of the EU Data Protection Directive is available at the following web address:

www.gigaset.com/privacy-policy

Environment

Environmental management system

Further information on environmentally friendly products and processes is available on the Internet at www.gigaset.com.



Gigaset Technologies GmbH is certified pursuant to the international standards ISO 14001 and ISO 9001.

ISO 14001 (Environment): certified since 13 May 2024 by TÜV SÜD Management Service GmbH.

ISO 9001 (Quality): certified since 13 May 2024 by TÜV SÜD Management Service GmbH.

Disposal

Batteries should not be disposed of in general household waste. Observe the local waste disposal regulations, details of which can be obtained from your local authority.

All electrical and electronic products should be disposed of separately from the municipal waste stream via designated collection facilities appointed by the government or the local authorities.



This crossed-out wheeled bin symbol on the product means the product is covered by the European Directive 2012/19/EU.

UK: The Waste Electrical and Electronic Equipment Regulations 2013.

The correct disposal and separate collection of your old appliance will help prevent potential negative consequences for the environment and human health. It is a precondition for reuse and recycling of used electrical and electronic equipment.

For more detailed information about disposal of your old appliance, please contact your local council refuse centre or the original supplier of the product.

Product care

Wipe the appliance with a **damp** cloth or an anti-static cloth. Do not use any solvents or microfiber cloths.

Never use a dry cloth: there is a risk of static charge.

In rare cases, contact of the device with chemical substances can lead to changes in the surface. Due to the large number of chemicals available on the market, not all substances can be tested.

Impairments to high-gloss surfaces can be cleared by careful removal using cell phone display polishes.

Contact with liquid

If the device has come into contact with liquid:

- 1 Disconnect all cables from the device.
- 2 Remove the batteries and leave the battery compartment open.
- 3 Drain the liquid from the device.
- 4 Pat all parts dry.
- 5 Then store the device in a dry, warm place for at least 72 hours with the battery compartment open and the keypad facing down (if present) (**not** in a: microwave, oven, etc.).
- 6 Only switch the device on again when it is dry.

In most cases, it is possible to restart the device when it is completely dry.

Technical data

Batteries (handset)

Technology: 2 x AAA NiMH

Voltage: 1.2 V

Capacity: 750 mAh

Operating times/Charging times of the handset

The operating time of your Gigaset depends on the battery capacity, age of the batteries and user behavior. All times are maximum times.

Standby time (hours)	300
Talk time (hours)	14
Operating time with 1.5 hours of conversation per day (hours)	95
Charging time in charging cradle (hours)	9.5

Power consumption of the handset in the charging cradle

When charging: Approx. 1.50 W

To maintain the charge status: Approx. 0.50 W

Power consumption of the base unit

Standby mode

- Handset in the base unit Approx. 0.90 W

- Handset outside the base unit Approx. 0.60 W

During a conversation: Approx. 0.70 W

General technical data

DECT standard	Is supported
GAP standard	Is supported
Number of channels	60 duplex channels
Radio frequency range	1880-1900 MHz
Duplex process	Time division multiplex, 10 ms frame length
Repetition frequency of the transmission pulse	100 Hz
Length of the transmission pulse	370 μ s
Channel grid	1728 kHz
Bit rate	1152 kbit/s
Modulation	GFSK
Language coding	32 kbit/s
Transmission power	10 mW average power per channel, power 250 mW pulse power
Range	Up to 50 m indoors, up to 300 m outdoors
Power supply, base station	230 V ~/50 Hz
Ambient conditions during operation	+5 °C to +45 °C; 20 % to 75 % relative humidity
Dialing method	DTMF (tone dialing)/IWW (pulse dialing)

Power adapter

Manufacturer	Salom Electric (Xiamen) Co. Ltd. Commercial register: 91350200612003878C 31 Building, Huli Industrial District, Xiamen, Fujian 361006, P.R. China	
	Salcomp (Shenzen) Co. Ltd. Commercial register: 91440300618932635P Salcomp Road, Furond Industrial Area, Xinqiao, Shajing, Baoan District, Shenzen 518125 China	
	LEADER ELECTRONICS Commercial register: 913211007039359372 8F, No.138 Ln. 235 Baoqio Rd. Xindian Dist. New Taipei City 23145, Taiwan	
	Dongguan City Gangqi Electronics Co. Ltd. Commercial register: 914419007929512928 Privately Operated Industrial District, ShiYong, 523600 Heng Li Town, Dong Guan, Guangdong, People's Republic of China	
	Handset	Base unit
Model ID	C705 (EU variant) C710 (UK variant)	C707/C769 (EU variant) C771/C785 (UK variant)
Input voltage	230 V	230 V
Input alternating current frequency	50 Hz	50 Hz
Output voltage	4 V	6.5 V
Output current	0.15 A	0.3 A
Output power	0.6 W	1.95 W
Average efficiency during use	> 46 %	> 71.5 %
Efficiency at low load (10 %)	Not relevant – only for output power > 10 W	Not relevant – only for output power > 10 W
Power consumption at zero load	< 0.10 W	< 0.10 W

Character set tables

The character set used in the handset depends on the language set.

Entering letters/characters

- ▶ Press the corresponding button several times.
- ▶ Press the Hash key [#] briefly to switch from "Abc" to "123", from "123" to "abc" and from "abc" to "ABC"
- ▶ Press the Hash key [#] longer . . . and the available characters for the key are available for selection one after the other

Standard font

Press the corresponding button several times.





	1x	2x	3x	4x	5x	6x	7x	8x	9x	10x
1	1									
2	a	b	c	2	ä	á	à	â	ã	ç
3	d	e	f	3	ë	é	è	ê		
4	g	h	i	4	ï	í	ì	î		
5	j	k	l	5						
6	m	n	o	6	ö	ñ	ó	ò	ô	õ
7	p	q	r	s	7	ß				
8	t	u	v	8	ü	ú	ù	û		
9	w	x	y	z	9	ÿ	ý	æ	ø	å
0	↵ ¹⁾	↵ ¹⁾	.	,	?	!	← ²⁾	0		

1) Space





2) Line break

Symbols





Symbols in the status bar

Symbol	Significance
	Reception strength, depending on the number of bars 1 - 100 %
	Charge status of the battery, depending on the bar length 0 - 100 % white: above 11 %; red: below 11 %; flashes red: Battery almost empty (approx. 5 minutes of talk time left)
	Battery is charging (current charge level): 0 % - 100 %
	Answering machine is activated
	Help call function deactivated







Display key symbols

Symbol	Significance
	Open redial list
	Delete text
	Open the phone book
	Copy number in the phone book

Symbols in the display when signaling . . .

Symbol	Significance
	external call
	internal call
	Establishing a connection (outgoing call)
	Connection established
	Connection terminated / connection cannot be established

Further display symbols

Symbol	Significance
	Missed calls
	New voice messages
	Action executed (green)
	Action failed (red)
	Information
	(Security) query
	Please wait ...

Index

-
- A**
- Advertisement
 - Anonymous..... 33
 - Unknown..... 33
 - Announcement
 - Recording..... 48
 - Announcement language..... 73
 - Answering machine
 - Record an announcement..... 48
 - Retrieving a call..... 47
 - switching on/off..... 44
 - Approval..... 84
 - Automatic call acceptance..... 66
-
- B**
- Base unit
 - connection..... 17
 - Resetting..... 69
 - Battery
 - charging..... 21
 - Boost key..... 59
 - Brightness
 - Time control..... 75
 - Broken display..... 13
 - Brokering
 - Two external calls..... 37
 - Button
 - on the base..... 9, 10
-
- C**
- Call
 - anonymously..... 33
 - in call list..... 39
 - incoming..... 29
 - Information in the call list..... 39
 - internal..... 31
 - Reject..... 29
 - Taking..... 29
 - Call acceptance, automatic..... 66
 - Call anonymously..... 33
 - Call caller back..... 35
 - Call forwarding..... 35
 - Call list
 - all calls..... 39
 - Calls received..... 39
 - Delete..... 40
 - Delete entry..... 40
 - Icons..... 39
 - Missed calls..... 39
 - Open..... 39
 - Outgoing calls..... 39
 - Call lists..... 39
 - Call number transmission
 - Temporary deactivation..... 33
 - Call waiting tone, external..... 34
 - Call, anonymous..... 33
 - Callback
 - Delete..... 35
 - Caller profiles..... 61
 - Calls received..... 39
 - Care of the device..... 89
 - Change country setting..... 59
 - Changing
 - System PIN..... 69
 - Changing the display language..... 58
 - Changing the PIN..... 69
 - Character set (handset)..... 93
 - Charging time of the handset..... 90
 - CLI, Calling Line Identification..... 33
 - CLIP, CLI Presentation..... 33
 - CLIR, CLI Restriction..... 33
 - CNIP, Calling Name Identification
 - Presentation..... 34
 - Color scheme..... 65
 - Conference..... 37
 - Terminate..... 38
 - Two external talks..... 37

- | | | | |
|-------------------------------------|----|-----------------------------------|--------|
| Contact | | Display | |
| create | 41 | broken | 13 |
| delete..... | 43 | Change display language | 58 |
| edit | 42 | Color scheme | 65 |
| search..... | 42 | External..... | 33 |
| Contact with liquid | 89 | Illumination | 65 |
| Control key | 25 | Screensaver..... | 64 |
| Create announcements for | | Settings | 64 |
| contacts | 74 | Symbols | 94, 95 |
| Customer Care..... | 84 | Display functions | 25 |
| Customer service..... | 84 | Display illumination | 65 |
| | | Display keys | 25 |
| <hr/> | | Functions..... | 25 |
| D | | Symbols | 94 |
| Data protection | 87 | Disposal..... | 88 |
| Date and time | | Do not disturb | 57 |
| setting on the mobile phone. 21, 58 | | | |
| Dial | | <hr/> | |
| from the phone book | 28 | E | |
| Dial number | | ECO DECT..... | 55 |
| from call list | 29 | Encryption | 68 |
| from the redial list | 28 | Ending a call..... | 30 |
| Dial phone number | | Enter characters | 93 |
| from phone book..... | 28 | Enter digits | 27 |
| Dialing | | Enter special letters | 27 |
| from the call lists | 29 | Enter text | 27 |
| from the redial list | 28 | Enter umlauts | 27 |
| Dialing call numbers | 28 | Entering special characters | 27 |
| Dialing method | 67 | Environment..... | 88 |
| Direct dialing keys..... | 71 | Extension for emergencies | |
| Assigning a phone number..... | 71 | EASY 500..... | 78 |
| Changing key assignment | 72 | EASY 500A..... | 81 |
| Direct extension | | EASY 500HX | 78 |
| EASY 500 procedure | 81 | Extension PIN | |
| EASY 500A procedure | | for EASY 500..... | 78 |
| Answering machine switched | | for EASY 500A..... | 81 |
| off | 83 | for EASY 500HX..... | 78 |
| Answering machine switched | | | |
| on | 82 | <hr/> | |
| EASY 500HX procedure..... | 81 | F | |
| Phone number | 80 | Flash times | 67 |
| | | Further functions | 52 |

-
- G**
 Getting started..... 15
 Guarantee Certificate..... 85
-
- H**
 Handset 11
 Change name..... 53
 Color scheme 65
 Deregistering..... 53
 Display illumination 65
 Display language..... 58
 Handset volume..... 60
 Handsfree volume 61
 Large font..... 65
 register..... 9, 10
 Resetting..... 68
 search..... 9, 10
 Handset phone book
 create a contact..... 41
 delete contact..... 43
 edit contact..... 42
 memory space 43
 open..... 41
 Order of entries 42
 Handsfree key 30
 Handsfree profiles 61
 Hearing
 prevent loss of 14
 Hearing aids 14
 Help 84
-
- I**
 Icons
 Status bar..... 94
 Inserting the
 battery..... 20
 Internal
 call..... 31
-
- K**
 Key
 Handsfree..... 30
 Key announcement..... 73
 Keys
 Control key..... 25
 Menu..... 25
-
- L**
 Language
 Change 58
 Large font..... 65
 LED call alert signal 76
 Lighting 65
 Liquid..... 89
 Logging off (handset)..... 53
 Login/Paging button 9, 10
 Loss of hearing 14
 Lowercase/Uppercase 27
-
- M**
 Making a call
 internal 31
 Making calls..... 28
 Max. range..... 55
 Medical equipment..... 14
 Memory space in the phone book . 43
 Menu key 25
 Missed calls 39
 Missed calls see Missed calls
-
- N**
 Network provider 32
 Network services,
 provider-specific..... 32
 Number
 Do not transmit..... 33
 Suppression 33
 Number announcement..... 74
 Number suppression..... 33

-
- O**
- Open the menu 26
 - Operating time of the handset..... 90
 - Outside line 66
-
- P**
- Paging 9, 10, 54
 - Phone book
 - delete..... 43
 - delete entry..... 43
 - Phone number
 - for extension 80
 - Phone number display 33
 - Phone number transfer
 - none 33
 - Phone number transmission..... 33
 - Power adapter 13, 92
 - Power consumption..... 90
 - Putting into operation, handset.... 20
 - Putting the handset
 - into operation 20
-
- Q**
- Query
 - End..... 36
 - external 36
-
- R**
- Radiation
 - Reduction 55
 - Radiation-free..... 55
 - Read out contacts..... 74
 - Record announcements..... 74
 - Recalling
 - Initiate..... 35
 - Redial list..... 28, 39
 - Ringing tones 62
 - Ringtone
 - Setting 62
 - Volume..... 62
 - Ringtone melody 62
 - Ringtones..... 62
-
- S**
- Safety information..... 13
 - Screensaver 64
 - Serious caller..... 77
 - Service provider s. Network provider
 - Set the brightness 75
 - Settings
 - Display..... 64
 - Display menu 58
 - Simple menu 77
 - SOS emergency call 22
 - cancel..... 23
 - Change/Delete number..... 24
 - Procedure 22
 - Save numbers 23
 - setting up 23
 - SOS key 22
 - Status bar
 - Icons..... 94
 - Switch network provider 32
 - Switch off the wireless module.... 55
 - Switching (network provider) 32
 - Switching call number transmission
 - on/off 33
 - Switching handsfree calling on/off 30
 - Switching listening in on/off 47
 - Symbol
 - for notes..... 5
 - Symbols
 - Display..... 94, 95
 - Display keys 94
-
- T**
- Technical data 91
 - Telephone
 - connection 15
-
- U**
- Uppercase/Lowercase 27

V	
VIP ringtone.....	41
Voice message	
listening on the handset	45
Voice messages	
Actions during playback	46
Volume	
Handset.....	60
Handset volume.....	60
Handsfree volume, handset	61
Loudspeaker	61

Issued by

**Gigaset Technologies GmbH
Frankenstraße 2, D-46395 Bocholt**

© Gigaset Technologies GmbH 2026

Subject to availability.

All rights reserved. Rights of modification reserved.

www.gigaset.com